



HELIOS · PREISSER

# SAMPLES SQUARES

SQUARE **WITH BASE**

SQUARE **WITHOUT BASE**



HIGH **QUALITY**

MADE IN **GERMANY**

Manufactured according to **DIN 875**

**Highest** precision:  
Accuracy **grade 0**

Blade length up to **2 meters**  
(Accuracy grade 2)

Made from **special** or **stainless** steel

More **highlights** from our range of **squares**



**ACUTE ANGLE**  
SQUARES



**MITRE SQUARES**



**BEVEL**  
**PROTRACTORS**

## 5. CHAPTER SQUARES, PROTRACTORS AND BEVEL PROTRACTORS

|     |  |
|-----|--|
| 154 | Squares with / without base                            |
| 158 | Steel squares  |
| 159 | Squares with hard and slim blade                       |
| 161 | Knife edge squares                                     |
| 162 | Inspection set   |
| 163 | Centre squares / Flange squares                        |
| 164 | Mitre / Acute angle squares                            |
| 166 | Squares for specific measuring tasks and target groups |
| 168 | Wooden cases   |
| 169 | Protractors  |
| 172 | Universal bevel protractors                            |

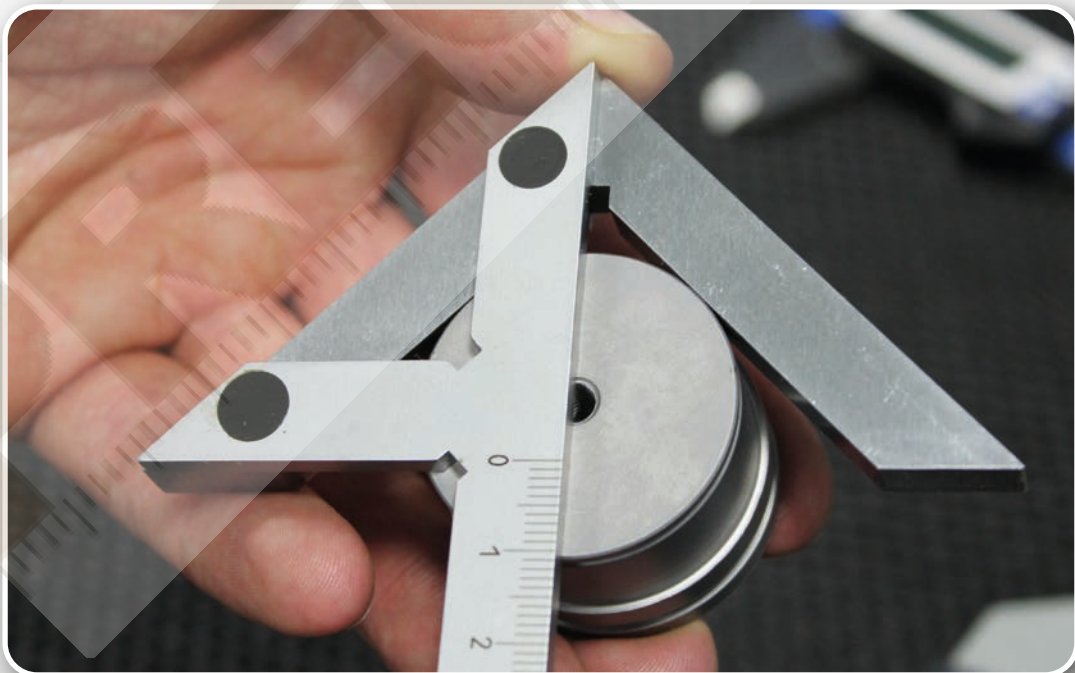



## 0368 Squares with base accuracy grade 0



|                        |   | Jaw length<br>mm | Cross-section<br>mm | Order no. | List price<br>EUR | DIN<br>875 |
|------------------------|---|------------------|---------------------|-----------|-------------------|------------|
| <b>Special steel</b>   |   |                  |                     |           |                   |            |
|                        |   | 75 x 50          | 15 x 5              | 0368 102  | 28.50             |            |
|                        |   | 100 x 70         | 20 x 5              | 0368 103  | 31.80             |            |
|                        |   | 150 x 100        | 25 x 5              | 0368 104  | 42.70             |            |
|                        |   | 200 x 130        | 30 x 6              | 0368 105  | 55.00             |            |
|                        |   | 250 x 165        | 35 x 7              | 0368 106  | 73.00             |            |
|                        |   | 300 x 200        | 40 x 8              | 0368 107  | 90.00             |            |
|                        |   | 400 x 265        | 45 x 10             | 0368 108  | 195.00            |            |
|                        |   | 500 x 330        | 50 x 10             | 0368 109  | 287.00            |            |
|                        |   | 600 x 400        | 50 x 10             | 0368 110  | 405.00            |            |
|                        |   | 750 x 500        | 60 x 12             | 0368 111  | 810.00            |            |
|                        | ▪ | 1000 x 660       | 70 x 15             | 0368 112  | 1362.00           |            |
| <b>Stainless steel</b> |   |                  |                     |           |                   |            |
|                        |   | 75 x 50          | 15 x 5              | 0368 202  | 55.00             |            |
|                        |   | 100 x 70         | 20 x 5              | 0368 203  | 65.00             |            |
|                        |   | 150 x 100        | 25 x 5              | 0368 204  | 88.00             |            |
|                        |   | 200 x 130        | 30 x 6              | 0368 205  | 119.00            |            |
|                        |   | 250 x 165        | 35 x 7              | 0368 206  | 166.00            |            |
|                        |   | 300 x 200        | 40 x 8              | 0368 207  | 214.00            |            |
|                        |   | 400 x 265        | 45 x 10             | 0368 208  | 331.00            |            |
|                        |   | 500 x 330        | 50 x 10             | 0368 209  | 457.00            |            |
|                        |   | 600 x 400        | 50 x 10             | 0368 210  | 679.00            |            |
|                        |   | 750 x 500        | 60 x 12             | 0368 211  | 1166.00           |            |
|                        | ▪ | 1000 x 660       | 70 x 15             | 0368 212  | 2472.00           |            |

### Model

- DIN 875
- Accuracy grade 0
- For exact angle testing (for example: tool making)

### Delivery

- Cardboard box
- From blade length 1000 mm in a transportation box

## 0369 Squares without base accuracy grade 0



|                        |   | Jaw length<br>mm | Cross-section<br>mm | Order no. | List price<br>EUR | DIN<br>875 |
|------------------------|---|------------------|---------------------|-----------|-------------------|------------|
| <b>Special steel</b>   |   |                  |                     |           |                   |            |
|                        |   | 75 x 50          | 15 x 5              | 0369 102  | 19.80             |            |
|                        |   | 100 x 70         | 20 x 5              | 0369 103  | 21.40             |            |
|                        |   | 150 x 100        | 25 x 5              | 0369 104  | 26.10             |            |
|                        |   | 200 x 130        | 30 x 6              | 0369 105  | 36.10             |            |
|                        |   | 250 x 165        | 35 x 7              | 0369 106  | 48.80             |            |
|                        |   | 300 x 200        | 40 x 8              | 0369 107  | 68.00             |            |
|                        |   | 400 x 265        | 45 x 10             | 0369 108  | 137.00            |            |
|                        |   | 500 x 330        | 50 x 10             | 0369 109  | 179.00            |            |
|                        |   | 600 x 400        | 50 x 10             | 0369 110  | 286.00            |            |
|                        |   | 750 x 500        | 60 x 12             | 0369 111  | 530.00            |            |
|                        | ▪ | 1000 x 660       | 70 x 15             | 0369 112  | 945.00            |            |
| <b>Stainless steel</b> |   |                  |                     |           |                   |            |
|                        |   | 75 x 50          | 15 x 5              | 0369 202  | 36.60             |            |
|                        |   | 100 x 70         | 20 x 5              | 0369 203  | 44.30             |            |
|                        |   | 150 x 100        | 25 x 5              | 0369 204  | 55.00             |            |
|                        |   | 200 x 130        | 30 x 6              | 0369 205  | 84.00             |            |
|                        |   | 250 x 165        | 35 x 7              | 0369 206  | 110.00            |            |
|                        |   | 300 x 200        | 40 x 8              | 0369 207  | 135.00            |            |
|                        |   | 400 x 265        | 45 x 10             | 0369 208  | 228.00            |            |
|                        |   | 500 x 330        | 50 x 10             | 0369 209  | 318.00            |            |
|                        |   | 600 x 400        | 50 x 10             | 0369 210  | 534.00            |            |
|                        |   | 750 x 500        | 60 x 12             | 0369 211  | 995.00            |            |
|                        | ▪ | 1000 x 660       | 70 x 15             | 0369 212  | 1866.00           |            |

### Model

- DIN 875
- Accuracy grade 0
- For exact angle testing (for example: tool making)

### Delivery

- Cardboard box
- From blade length 1000 mm in a transportation box



## 0385 Inspection squares with base accuracy grade 0, hardened



### Model

- DIN 875
- Accuracy grade 0
- For exact angle testing (for example: tool making)

### Delivery

- Cardboard box

**DIN  
875**

|                        | Jaw length<br>mm | Cross-section<br>mm | Order no. | List price<br>EUR |
|------------------------|------------------|---------------------|-----------|-------------------|
| <b>Special steel</b>   |                  |                     |           |                   |
|                        | 50 x 40          | 15 x 4              | 0385 102  | 28.60             |
|                        | 75 x 50          | 15 x 4              | 0385 103  | 30.50             |
|                        | 100 x 70         | 20 x 5              | 0385 104  | 36.50             |
|                        | 150 x 100        | 25 x 6              | 0385 105  | 55.00             |
|                        | 200 x 130        | 30 x 7              | 0385 106  | 76.00             |
|                        | 300 x 200        | 40 x 8              | 0385 108  | 132.00            |
| <b>Stainless steel</b> |                  |                     |           |                   |
|                        | 50 x 40          | 15 x 4              | 0385 202  | 39.60             |
|                        | 75 x 50          | 15 x 4              | 0385 203  | 44.00             |
|                        | 100 x 70         | 20 x 5              | 0385 204  | 55.00             |
|                        | 150 x 100        | 25 x 6              | 0385 205  | 73.00             |
|                        | 200 x 130        | 30 x 7              | 0385 206  | 93.00             |
|                        | 300 x 200        | 40 x 8              | 0385 208  | 137.00            |

## 0386 Inspection squares without base accuracy grade 0, hardened



### Model

- DIN 875
- Accuracy grade 0
- For exact angle testing (for example: tool making)

### Delivery

- Cardboard box

**DIN  
875**

5

|                        | Jaw length<br>mm | Cross-section<br>mm | Order no. | List price<br>EUR |
|------------------------|------------------|---------------------|-----------|-------------------|
| <b>Special steel</b>   |                  |                     |           |                   |
|                        | 50 x 40          | 15 x 4              | 0386 102  | 21.60             |
|                        | 75 x 50          | 15 x 4              | 0386 103  | 23.20             |
|                        | 100 x 70         | 20 x 5              | 0386 104  | 28.30             |
|                        | 150 x 100        | 25 x 6              | 0386 105  | 35.10             |
|                        | 200 x 130        | 30 x 7              | 0386 106  | 45.20             |
|                        | 300 x 200        | 40 x 8              | 0386 108  | 87.00             |
| <b>Stainless steel</b> |                  |                     |           |                   |
|                        | 50 x 40          | 15 x 4              | 0386 202  | 27.30             |
|                        | 75 x 50          | 15 x 4              | 0386 203  | 30.90             |
|                        | 100 x 70         | 20 x 5              | 0386 204  | 36.50             |
|                        | 150 x 100        | 25 x 6              | 0386 205  | 47.30             |
|                        | 200 x 130        | 30 x 7              | 0386 206  | 61.00             |
|                        | 300 x 200        | 40 x 8              | 0386 208  | 121.00            |



## 0370 Squares with base accuracy grade 1



### Model

- DIN 875
- Accuracy grade 1
- For angle testing in production and factory

### Delivery

- Cardboard box
- From blade length 1000 mm in a transportation box

|                        |   | Jaw length<br>mm | Cross-section<br>mm | Order no. | List price<br>EUR |
|------------------------|---|------------------|---------------------|-----------|-------------------|
| <b>Special steel</b>   |   |                  |                     |           |                   |
|                        |   | 75 x 50          | 15 x 5              | 0370 102  | 17.60             |
|                        |   | 100 x 70         | 20 x 5              | 0370 103  | 19.80             |
|                        |   | 150 x 100        | 25 x 5              | 0370 104  | 26.50             |
|                        |   | 200 x 130        | 30 x 6              | 0370 105  | 33.70             |
|                        |   | 250 x 165        | 35 x 7              | 0370 106  | 45.10             |
|                        |   | 300 x 200        | 40 x 8              | 0370 107  | 57.00             |
|                        |   | 400 x 265        | 45 x 10             | 0370 108  | 112.00            |
|                        |   | 500 x 330        | 50 x 10             | 0370 109  | 164.00            |
|                        |   | 600 x 400        | 50 x 10             | 0370 110  | 232.00            |
|                        |   | 750 x 500        | 60 x 12             | 0370 111  | 463.00            |
|                        | ▪ | 1000 x 660       | 70 x 15             | 0370 112  | 778.00            |
| <b>Stainless steel</b> |   |                  |                     |           |                   |
|                        |   | 75 x 50          | 15 x 5              | 0370 202  | 19.40             |
|                        |   | 100 x 70         | 20 x 5              | 0370 203  | 21.70             |
|                        |   | 150 x 100        | 25 x 5              | 0370 204  | 32.70             |
|                        |   | 200 x 130        | 30 x 6              | 0370 205  | 42.90             |
|                        |   | 250 x 165        | 35 x 7              | 0370 206  | 59.00             |
|                        |   | 300 x 200        | 40 x 8              | 0370 207  | 78.00             |
|                        |   | 400 x 265        | 45 x 10             | 0370 208  | 198.00            |
|                        |   | 500 x 330        | 50 x 10             | 0370 209  | 254.00            |
|                        |   | 600 x 400        | 50 x 10             | 0370 210  | 395.00            |
|                        |   | 750 x 500        | 60 x 12             | 0370 211  | 611.00            |
|                        | ▪ | 1000 x 660       | 70 x 15             | 0370 212  | 988.00            |

**DIN  
875**

## 0371 Squares without base accuracy grade 1



### Model

- DIN 875
- Accuracy grade 1
- For angle testing in production and factory

### Delivery

- Cardboard box
- From blade length 1000 mm in a transportation box

|                        |   | Jaw length<br>mm | Cross-section<br>mm | Order no. | List price<br>EUR |
|------------------------|---|------------------|---------------------|-----------|-------------------|
| <b>Special steel</b>   |   |                  |                     |           |                   |
|                        |   | 75 x 50          | 15 x 5              | 0371 102  | 12.60             |
|                        |   | 100 x 70         | 20 x 5              | 0371 103  | 13.90             |
|                        |   | 150 x 100        | 25 x 5              | 0371 104  | 17.00             |
|                        |   | 200 x 130        | 30 x 6              | 0371 105  | 21.90             |
|                        |   | 250 x 165        | 35 x 7              | 0371 106  | 30.50             |
|                        |   | 300 x 200        | 40 x 8              | 0371 107  | 38.90             |
|                        |   | 400 x 265        | 45 x 10             | 0371 108  | 93.00             |
|                        |   | 500 x 330        | 50 x 10             | 0371 109  | 121.00            |
|                        |   | 600 x 400        | 50 x 10             | 0371 110  | 168.00            |
|                        |   | 750 x 500        | 60 x 12             | 0371 111  | 316.00            |
|                        | ▪ | 1000 x 660       | 70 x 15             | 0371 112  | 541.00            |
| <b>Stainless steel</b> |   |                  |                     |           |                   |
|                        |   | 75 x 50          | 15 x 5              | 0371 202  | 13.80             |
|                        |   | 100 x 70         | 20 x 5              | 0371 203  | 15.30             |
|                        |   | 150 x 100        | 25 x 5              | 0371 204  | 18.60             |
|                        |   | 200 x 130        | 30 x 6              | 0371 205  | 27.90             |
|                        |   | 250 x 165        | 35 x 7              | 0371 206  | 37.80             |
|                        |   | 300 x 200        | 40 x 8              | 0371 207  | 47.40             |
|                        |   | 400 x 265        | 45 x 10             | 0371 208  | 156.00            |
|                        |   | 500 x 330        | 50 x 10             | 0371 209  | 198.00            |
|                        |   | 600 x 400        | 50 x 10             | 0371 210  | 304.00            |
|                        |   | 750 x 500        | 60 x 12             | 0371 211  | 556.00            |
|                        | ▪ | 1000 x 660       | 70 x 15             | 0371 212  | 896.00            |

**DIN  
875**



## 0372 Squares with base accuracy grade 2



### Model

- Special steel
- DIN 875
- Accuracy grade 2
- For angle testing in production and factory

### Delivery

- Cardboard box
- From blade length 1500 mm in a transportation box

DIN  
875

| ☒ ☒ | Jaw length<br>mm | Cross-section<br>mm | Order no. | List price<br>EUR |
|-----|------------------|---------------------|-----------|-------------------|
|     | 75 x 50          | 15 x 5              | 0372 102  | 14.10             |
|     | 100 x 70         | 20 x 5              | 0372 103  | 15.80             |
|     | 150 x 100        | 25 x 5              | 0372 104  | 21.20             |
|     | 200 x 130        | 30 x 6              | 0372 105  | 27.00             |
|     | 250 x 165        | 35 x 7              | 0372 106  | 36.10             |
|     | 300 x 175        | 35 x 7              | 0372 107  | 44.90             |
|     | 400 x 200        | 35 x 7              | 0372 108  | 67.00             |
|     | 500 x 250        | 40 x 8              | 0372 109  | 82.00             |
|     | 600 x 300        | 40 x 8              | 0372 110  | 108.00            |
|     | 750 x 375        | 45 x 10             | 0372 111  | 136.00            |
|     | 1000 x 500       | 50 x 10             | 0372 112  | 198.00            |
| ▪   | 1500 x 750       | 60 x 12             | 0372 113  | 867.00            |
| ▪   | 2000 x 1000      | 60 x 12             | 0372 114  | 1071.00           |

## 0373 Squares without base accuracy grade 2



### Model

- Special steel
- DIN 875
- Accuracy grade 2
- For angle testing in production and factory

### Delivery

- Cardboard box
- From blade length 1500 mm in a transportation box

DIN  
875

5

| ☒ ☒ | Jaw length<br>mm | Cross-section<br>mm | Order no. | List price<br>EUR |
|-----|------------------|---------------------|-----------|-------------------|
|     | 75 x 50          | 15 x 5              | 0373 102  | 10.10             |
|     | 100 x 70         | 20 x 5              | 0373 103  | 11.10             |
|     | 150 x 100        | 25 x 5              | 0373 104  | 13.60             |
|     | 200 x 130        | 30 x 6              | 0373 105  | 17.50             |
|     | 250 x 165        | 35 x 7              | 0373 106  | 22.50             |
|     | 300 x 175        | 35 x 7              | 0373 107  | 30.30             |
|     | 400 x 200        | 35 x 7              | 0373 108  | 47.90             |
|     | 500 x 250        | 40 x 8              | 0373 109  | 67.00             |
|     | 600 x 300        | 40 x 8              | 0373 110  | 86.00             |
|     | 750 x 375        | 45 x 10             | 0373 111  | 106.00            |
|     | 1000 x 500       | 50 x 10             | 0373 112  | 164.00            |
| ▪   | 1500 x 750       | 60 x 12             | 0373 113  | 788.00            |
| ▪   | 2000 x 1000      | 60 x 12             | 0373 114  | 947.00            |



## 0374 Steel squares with base



### Model

- Special steel, zinc coated
- Factory standard
- Simple design for angle test in steel and metal construction

### Delivery

- Cardboard box
- From blade length 1500 mm in a transportation box

| ✂ | 📏 | Jaw length<br>mm | Cross-section<br>mm | Order no. | List price<br>EUR |
|---|---|------------------|---------------------|-----------|-------------------|
|   |   | 100 x 70         | 20 x 5              | 0374 404  | 11.90             |
|   |   | 150 x 100        | 20 x 5              | 0374 408  | 13.30             |
|   |   | 200 x 130        | 20 x 5              | 0374 410  | 16.10             |
|   |   | 250 x 160        | 25 x 5              | 0374 412  | 19.40             |
|   |   | 300 x 180        | 25 x 5              | 0374 414  | 23.70             |
|   |   | 400 x 230        | 30 x 5              | 0374 416  | 29.90             |
|   |   | 500 x 280        | 30 x 5              | 0374 418  | 39.70             |
|   |   | 600 x 330        | 30 x 5              | 0374 420  | 54.00             |
|   |   | 750 x 375        | 30 x 5              | 0374 424  | 64.00             |
|   |   | 1000 x 500       | 30 x 5              | 0374 428  | 96.00             |
|   | ▪ | 1500 x 750       | 40 x 5              | 0374 430* | 225.00            |
|   | ▪ | 2000 x 1000      | 40 x 5              | 0374 432* | 330.00            |

\*polished

## 0375 Steel squares without base



### Model

- Special steel, zinc coated
- Factory standard
- Simple design for angle test in steel and metal construction

### Delivery

- Cardboard box
- From blade length 1500 mm in a transportation box

| ✂ | 📏 | Jaw length<br>mm | Cross-section<br>mm | Order no. | List price<br>EUR |
|---|---|------------------|---------------------|-----------|-------------------|
|   |   | 100 x 70         | 20 x 5              | 0375 404  | 8.70              |
|   |   | 150 x 100        | 20 x 5              | 0375 408  | 9.20              |
|   |   | 200 x 130        | 20 x 5              | 0375 410  | 9.70              |
|   |   | 250 x 160        | 25 x 5              | 0375 412  | 11.90             |
|   |   | 300 x 180        | 25 x 5              | 0375 414  | 13.00             |
|   |   | 400 x 230        | 30 x 5              | 0375 416  | 17.90             |
|   |   | 500 x 280        | 30 x 5              | 0375 418  | 19.80             |
|   |   | 600 x 330        | 30 x 5              | 0375 420  | 24.30             |
|   |   | 750 x 375        | 30 x 5              | 0375 424  | 28.80             |
|   |   | 1000 x 500       | 30 x 5              | 0375 428  | 37.20             |
|   | ▪ | 1500 x 750       | 40 x 5              | 0375 430* | 109.00            |
|   | ▪ | 2000 x 1000      | 40 x 5              | 0375 432* | 164.00            |

\*polished



## 0376 Squares with hard and slim blade, accuracy grade 1



### Model

### Delivery

DIN  
875

- Special steel
- DIN 875
- Accuracy grade 1
- For angle testing in production and factory

- Cardboard box



| ✂ | ☒ | Jaw length<br>mm | Cross section with<br>narrow beam<br>mm | Cross section with<br>wide beam<br>mm | Order no. | List price<br>EUR |
|---|---|------------------|---|---------------------------------------|-----------|-------------------|
|   |   | 75 x 50          | 14 x 3                                  | 14 x 10                               | 0376 102  | 13.90             |
|   |   | 100 x 70         | 16 x 3                                  | 16 x 10                               | 0376 103  | 14.80             |
|   |   | 150 x 100        | 22 x 3                                  | 20 x 12                               | 0376 104  | 18.60             |
|   |   | 200 x 130        | 24 x 3                                  | 24 x 14                               | 0376 105  | 30.60             |

## 0376 Squares with hard and slim blade, accuracy grade 2



### Model

### Delivery

DIN  
875

- Special steel
- DIN 875
- Accuracy grade 2
- For angle testing in production and factory

- Cardboard box



| ✂ | ☒ | Jaw length<br>mm | Cross section with<br>narrow beam<br>mm | Cross section with<br>wide beam<br>mm | Order no. | List price<br>EUR |
|---|---|------------------|---|---------------------------------------|-----------|-------------------|
|   |   | 75 x 50          | 14 x 2                                  | 14 x 10                               | 0376 112  | 13.00             |
|   |   | 100 x 70         | 18 x 2                                  | 16 x 10                               | 0376 113  | 13.80             |
|   |   | 150 x 100        | 22 x 3                                  | 20 x 12                               | 0376 114  | 16.70             |
|   |   | 200 x 130        | 24 x 3                                  | 24 x 14                               | 0376 115  | 23.40             |
|   |   | 250 x 160        | 28 x 3                                  | 28 x 16                               | 0376 116  | 28.90             |
|   |   | 300 x 175        | 30 x 3                                  | 32 x 18                               | 0376 117  | 34.40             |



## 0390 Squares with hard and slim blade, hardened, accuracy grade 0



### Model

- DIN 875
- Accuracy grade 0
- For exact angle testing (for example: tool making)

### Delivery

- Cardboard box

DIN  
875



| ▶                      | ☒ | Jaw length<br>mm | Cross section with<br>narrow beam<br>mm | Cross section with<br>wide beam<br>mm | Order no. | List price<br>EUR |
|------------------------|---|------------------|---|---------------------------------------|-----------|-------------------|
| <b>Special steel</b>   |   |                  |   |                                       |           |                   |
|                        |   | 50 x 40          | 16 x 2                                  | 14 x 10                               | 0390 102  | 40.80             |
|                        |   | 75 x 50          | 18 x 2                                  | 14 x 10                               | 0390 103  | 40.80             |
|                        |   | 100 x 70         | 18 x 2                                  | 16 x 10                               | 0390 104  | 47.30             |
|                        |   | 150 x 100        | 22 x 3                                  | 20 x 12                               | 0390 105  | 60.00             |
|                        |   | 200 x 130        | 26 x 3                                  | 24 x 14                               | 0390 106  | 82.00             |
|                        |   | 300 x 200        | 32 x 3                                  | 30 x 18                               | 0390 108  | 137.00            |
| <b>Stainless steel</b> |   |                  |   |                                       |           |                   |
|                        |   | 50 x 40          | 16 x 2                                  | 14 x 10                               | 0390 202  | 54.00             |
|                        |   | 75 x 50          | 18 x 2                                  | 14 x 10                               | 0390 203  | 61.00             |
|                        |   | 100 x 70         | 18 x 2                                  | 16 x 10                               | 0390 204  | 78.00             |
|                        |   | 150 x 100        | 22 x 3                                  | 20 x 12                               | 0390 205  | 101.00            |
|                        |   | 200 x 130        | 26 x 3                                  | 24 x 14                               | 0390 206  | 126.00            |
|                        |   | 300 x 200        | 32 x 3                                  | 30 x 18                               | 0390 208  | 193.00            |

## 0391 Knife edge squares with hard and slim blade, hardened, accuracy grade 00



### Model

- With knife edge
- DIN 875
- Accuracy grade 00
- For exact flatness testing (for example: in production)

### Delivery

- Cardboard box

DIN  
875



| ▶  | ☒ | Jaw length<br>mm | Cross section with<br>narrow beam<br>mm | Cross section with<br>wide beam<br>mm | Order no. | List price<br>EUR |
|--|---|------------------|---|---------------------------------------|-----------|-------------------|
| <b>Special steel, non-glare knife edge</b> |   |                  |   |                                       |           |                   |
|  |   | 50 x 40          | 16 x 2                                  | 14 x 10                               | 0391 102  | 64.00             |
|  |   | 75 x 50          | 18 x 2                                  | 14 x 10                               | 0391 103  | 64.00             |
|  |   | 100 x 70         | 18 x 2                                  | 16 x 10                               | 0391 104  | 83.00             |
|  |   | 150 x 100        | 22 x 3                                  | 20 x 12                               | 0391 105  | 104.00            |
|  |   | 200 x 130        | 26 x 3                                  | 24 x 14                               | 0391 106  | 140.00            |
|  |   | 300 x 200        | 32 x 3                                  | 30 x 18                               | 0391 108  | 204.00            |
| <b>Stainless steel</b>                     |   |                  |   |                                       |           |                   |
|  |   | 50 x 40          | 16 x 2                                  | 14 x 10                               | 0391 202  | 76.00             |
|  |   | 75 x 50          | 18 x 2                                  | 14 x 10                               | 0391 203  | 85.00             |
|  |   | 100 x 70         | 18 x 2                                  | 16 x 10                               | 0391 204  | 96.00             |
|  |   | 150 x 100        | 22 x 3                                  | 20 x 12                               | 0391 205  | 123.00            |
|  |   | 200 x 130        | 26 x 3                                  | 24 x 14                               | 0391 206  | 158.00            |
|  |   | 300 x 200        | 32 x 3                                  | 30 x 18                               | 0391 208  | 256.00            |



## 0388 Knife edge squares, hardened, accuracy grade 00



### Model

- DIN 875
- Accuracy grade 00
- For exact angle and flatness testing (for example: tool making)

### Delivery

- Cardboard box

**DIN  
875**



|  | Jaw length<br>mm | Cross-section<br>mm | Order no. | List price<br>EUR |
|--|------------------|---------------------|-----------|-------------------|
| <b>Special steel, non-glare knife edge</b> |                  |                     |           |                   |
|  | 50 x 40          | 14 x 4              | 0388 102  | 22.80             |
|  | 75 x 50          | 15 x 4              | 0388 103  | 27.10             |
|  | 100 x 70         | 20 x 5              | 0388 104  | 32.40             |
|  | 150 x 100        | 25 x 6              | 0388 105  | 43.60             |
|  | 200 x 130        | 30 x 7              | 0388 106  | 61.00             |
|  | 300 x 200        | 40 x 8              | 0388 108  | 106.00            |
| <b>Stainless steel</b>                     |                  |                     |           |                   |
|  | 50 x 40          | 14 x 4              | 0388 202  | 27.10             |
|  | 75 x 50          | 15 x 4              | 0388 203  | 31.80             |
|  | 100 x 70         | 20 x 5              | 0388 204  | 38.40             |
|  | 150 x 100        | 25 x 6              | 0388 205  | 49.50             |
|  | 200 x 130        | 30 x 7              | 0388 206  | 74.00             |
|  | 300 x 200        | 40 x 8              | 0388 208  | 161.00            |
|  | 500 x 330        | 40 x 10             | 0388 210  | 762.00            |

## 0394 Knife edge squares



5

### Model

- **0394101**
- Reading parts are satin chrome finished
- Sliding knife 7 x 7 x 60 mm
- Angle  $\pm 5^\circ$
- Handle 40 x 23 x 9 mm
- For testing on short edges and grooves through the sliding knife edge

### Delivery

- Wooden case



0394 101

|  | Dimensions<br>mm | Cross-section<br>mm | Order no. | List price<br>EUR |
|--|------------------|---------------------|-----------|-------------------|
|  | 60 x 35 x 13     | 7 x 7 x 100         | 0394 101  | 239.00            |

| Accessories               | Order no. | List price<br>EUR |
|---------------------------|-----------|-------------------|
| Replacement rule for 0394 | 0394 104  | 43.20             |



## 0387 Knife edge squares



### Model

- Stainless steel
- DIN 875
- Accuracy grade 00
- Angle 90°
- Knife edge on the inside

### Delivery

- Cardboard box

**DIN  
875**

| ✕ | ☒ | Jaw length<br>mm | Cross section with<br>narrow beam<br>mm | Cross section with<br>wide beam<br>mm | Order no. | List price<br>EUR |
|---|---|------------------|---|---------------------------------------|-----------|-------------------|
|   |   | 25 x 20          | 5 x 3.5                                 | 6 x 3.5                               | 0387 200  | 20.20             |
|   |   | 40 x 28          | 5 x 3.5                                 | 8 x 3.5                               | 0387 201  | 20.20             |

## 0397 5 piece inspection set



### Model

set consisting of:

- Knife edge square, stainless steel 75 x 50 mm
- Knife edge square, stainless steel 40 x 28 mm
- Knife edge square, stainless steel 25 x 20 mm
- Knife edge rule, special steel 100 mm
- Gauge block scribe 60 x 9 x 9 mm

### Delivery

- Wooden case

| ✕ | ☒ | Order no. | List price<br>EUR |
|---|---|-----------|-------------------|
|   |   | 0397 101  | 208.00            |



## 0380 Centre squares

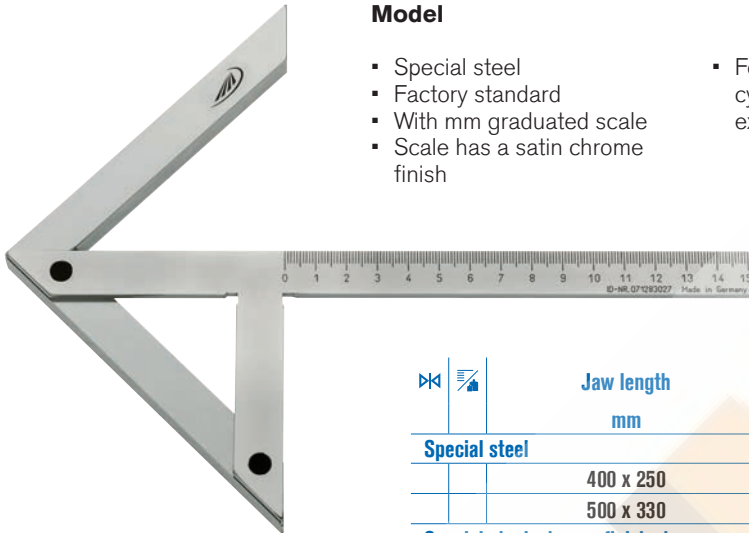

### Model

- Special steel
- Factory standard
- With mm graduated scale
- Scale has a satin chrome finish
- For marking the centre of cylindrical workpieces, for example spindles, slices

### Delivery

- Cardboard box

|                                       |  | Jaw length<br>mm | For shaft dia. up to<br>mm | Order no. | List price<br>EUR |
|---------------------------------------|--|------------------|----------------------------|-----------|-------------------|
| <b>Special steel</b>                  |  |                  |                            |           |                   |
|                                       |  | 400 x 250        | 380                        | 0380 108  | 296.00            |
|                                       |  | 500 x 330        | 530                        | 0380 109  | 526.00            |
| <b>Special steel, chrome finished</b> |  |                  |                            |           |                   |
|                                       |  | 100 x 70         | 90                         | 0380 103  | 65.00             |
|                                       |  | 150 x 130        | 190                        | 0380 104  | 77.00             |
|                                       |  | 200 x 150        | 220                        | 0380 105  | 96.00             |
|                                       |  | 250 x 160        | 230                        | 0380 106  | 106.00            |
|                                       |  | 300 x 180        | 280                        | 0380 107  | 115.00            |

## 0396 Flange squares

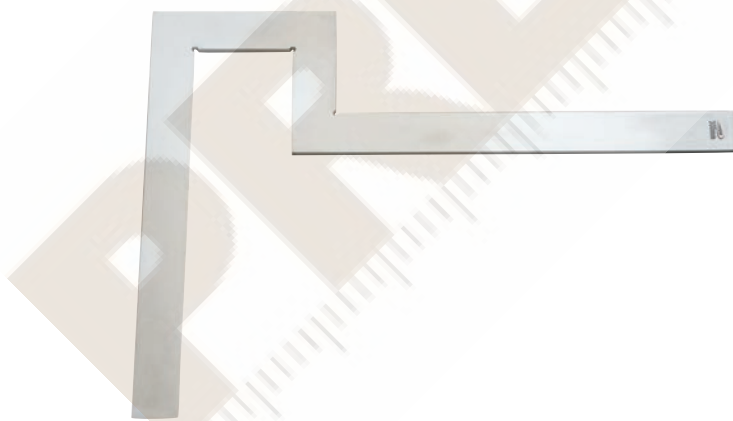

### Model

- Special steel, zinc coated
- Factory standard
- For accurately aligning flanges e.g. in plumbing and sanitary works in pipeline

### Delivery

- Cardboard box
- From blade length 600 mm in transportation box

|  |   | Jaw length<br>mm | Cross-section<br>mm | Order no. | List price<br>EUR |
|--|---|------------------|---------------------|-----------|-------------------|
|  |   | 300 x 300        | 30 x 5              | 0396 414  | 18.60             |
|  |   | 400 x 400        | 30 x 5              | 0396 416  | 22.00             |
|  |   | 500 x 500        | 30 x 5              | 0396 418  | 26.00             |
|  | ▪ | 600 x 600        | 30 x 5              | 0396 420  | 32.70             |
|  | ▪ | 800 x 800        | 30 x 5              | 0396 426  | 39.50             |



## 0395 Mitre squares 120°





### Model

- Special steel
- Factory standard

### Delivery

- Cardboard box

|   | Jaw length<br>mm | Cross-section<br>mm | Order no. | List price<br>EUR |
|---|------------------|---------------------|-----------|-------------------|
| <b>Flat, without base</b>   |                  |                     |           |                   |
|   | 50 x 50          | 15 x 5              | 0395 132  | 9.70              |
|   | 75 x 75          | 18 x 5              | 0395 133  | 12.40             |
|   | 100 x 100        | 20 x 5              | 0395 134  | 15.00             |

## 0395 Mitre squares 135°





### Model

- Special steel
- Factory standard

### Delivery

- Cardboard box

|   | Jaw length<br>mm | Cross-section<br>mm | Order no. | List price<br>EUR |
|---|------------------|---------------------|-----------|-------------------|
| <b>With base</b>  |                  |                     |           |                   |
|   | 120 x 80         | 20 x 5              | 0395 142  | 21.60             |
|   | 150 x 100        | 20 x 5              | 0395 143  | 24.40             |
|   | 200 x 130        | 25 x 5              | 0395 144  | 31.80             |
| <b>Flat, without base</b>   |                  |                     |           |                   |
|   | 50 x 50          | 15 x 5              | 0395 136  | 9.70              |
|   | 75 x 75          | 18 x 5              | 0395 137  | 12.40             |
|   | 100 x 100        | 20 x 5              | 0395 138  | 15.00             |
|   | 120 x 80         | 20 x 5              | 0395 146  | 15.90             |
|   | 150 x 100        | 20 x 5              | 0395 147  | 21.60             |
|   | 200 x 130        | 25 x 5              | 0395 148  | 29.10             |



## 0395 Acute angle squares 60°



### Model

- Special steel
- Factory standard

### Delivery

- Cardboard box

|                           | Jaw length<br>mm | Cross-section<br>mm | Order no. | List price<br>EUR |
|---------------------------|------------------|---------------------|-----------|-------------------|
| <b>With base</b>          |                  |                     |           |                   |
|                           | 120 x 80         | 20 x 5              | 0395 122  | 29.90             |
|                           | 150 x 100        | 20 x 5              | 0395 123  | 34.20             |
|                           | 200 x 130        | 25 x 5              | 0395 124  | 45.80             |
| <b>Flat, without base</b> |                  |                     |           |                   |
|                           | 120 x 80         | 20 x 5              | 0395 126  | 21.50             |
|                           | 150 x 100        | 20 x 5              | 0395 127  | 23.90             |
|                           | 200 x 130        | 25 x 5              | 0395 128  | 33.60             |

## 0395 Acute angle squares 45°



### Model

- Special steel
- Factory standard

### Delivery

- Cardboard box

|                           | Jaw length<br>mm | Cross-section<br>mm | Order no. | List price<br>EUR |
|---------------------------|------------------|---------------------|-----------|-------------------|
| <b>With base</b>          |                  |                     |           |                   |
|                           | 120 x 80         | 20 x 5              | 0395 102  | 31.60             |
|                           | 150 x 100        | 20 x 5              | 0395 103  | 35.10             |
|                           | 200 x 130        | 25 x 5              | 0395 104  | 47.30             |
| <b>Flat, without base</b> |                  |                     |           |                   |
|                           | 120 x 80         | 20 x 5              | 0395 106  | 22.30             |
|                           | 150 x 100        | 20 x 5              | 0395 107  | 24.40             |
|                           | 200 x 130        | 25 x 5              | 0395 108  | 35.10             |





## 0396 Carpenters squares

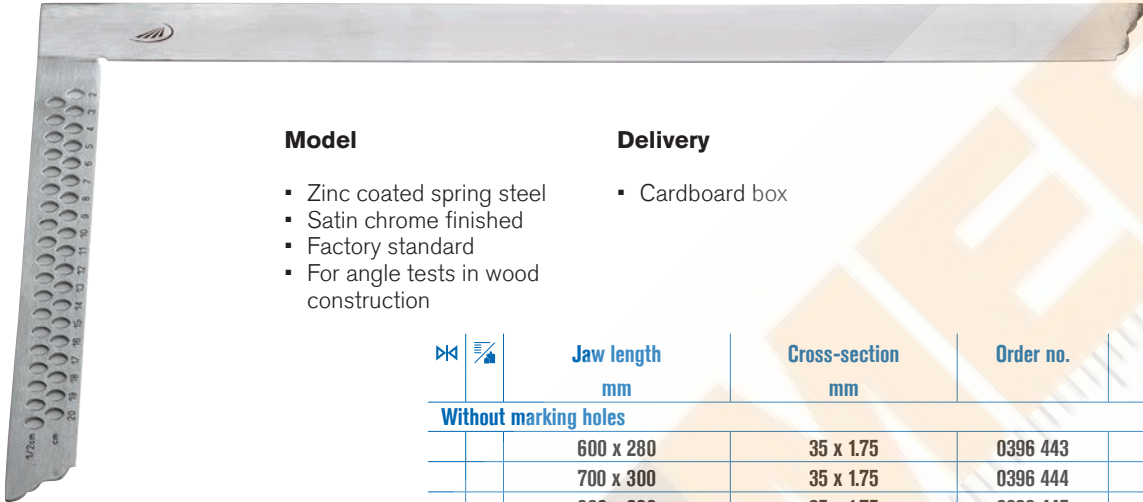



### Model

- Zinc coated spring steel
- Satin chrome finished
- Factory standard
- For angle tests in wood construction

### Delivery

- Cardboard box

|  |  | Jaw length<br>mm | Cross-section<br>mm | Order no. | List price<br>EUR |
|---|---|------------------|---------------------|-----------|-------------------|
| <b>Without marking holes</b>  |   |                  |                     |           |                   |
|   |   | 600 x 280        | 35 x 1.75           | 0396 443  | 11.90             |
|   |   | 700 x 300        | 35 x 1.75           | 0396 444  | 14.00             |
|   |   | 800 x 320        | 35 x 1.75           | 0396 445  | 15.20             |
|   |   | 1000 x 380       | 35 x 1.75           | 0396 446  | 19.50             |
| <b>With marking holes</b>   |   |                  |                     |           |                   |
|   |   | 600 x 280        | 35 x 1.75           | 0396 453  | 14.90             |
|   |   | 700 x 300        | 35 x 1.75           | 0396 454  | 16.80             |
|   |   | 800 x 320        | 35 x 1.75           | 0396 455  | 18.80             |
|   |   | 1000 x 380       | 35 x 1.75           | 0396 456  | 22.90             |

## 0396 Alpha squares with marking holes

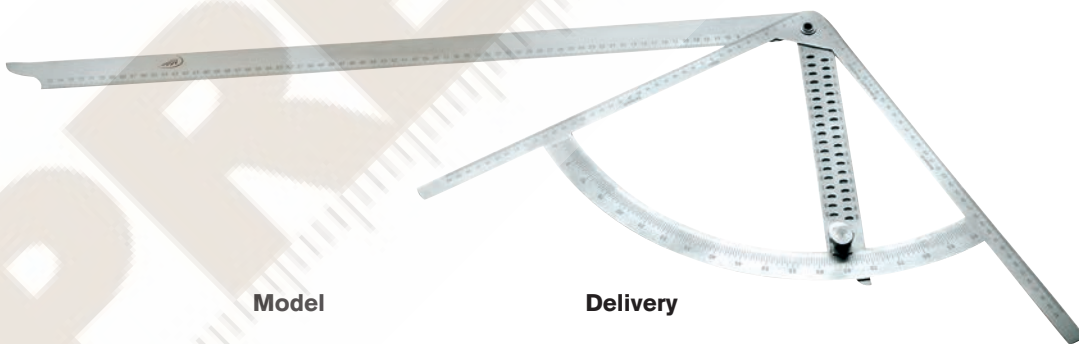

### Model

- Stainless steel
- Long blade with mm graduation, short blade used as adjustable protractor and for marking and production of wood joints 0°-90°

### Delivery

- Cardboard box

|  |  | Jaw length<br>mm | Cross-section<br>mm | Order no. | List price<br>EUR |
|---|---|------------------|---------------------|-----------|-------------------|
|   |   | 430 x 795        | 35                  | 0396 290  | 109.00            |



## 0396 Joiner squares with mitre

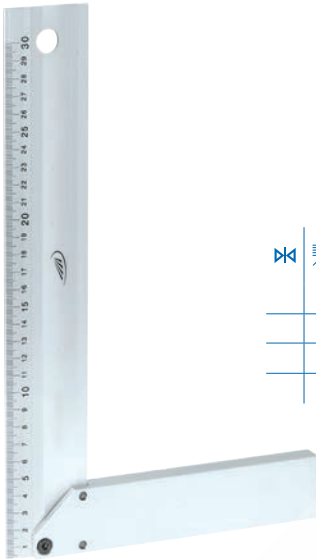

### Model

- Aluminium
- mm graduation

### Delivery

- Cardboard box

|  | Jaw length<br>mm | Cross section with<br>narrow beam<br>mm | Cross section with<br>wide beam<br>mm | Order no. | List price<br>EUR |
|--|------------------|---|---------------------------------------|-----------|-------------------|
|  | 250 x 148        | 40 x 14                                 | 50 x 5                                | 0396 982  | 13.50             |
|  | 300 x 164        | 40 x 14                                 | 50 x 5                                | 0396 983  | 15.90             |
|  | 400 x 195        | 40 x 14                                 | 50 x 5                                | 0396 984  | 19.00             |

## 0396 Adjustable square



### Model

- Special steel, zinc coated
- Satin chrome finished
- Screw hinge
- For transferring, marking and setting of individual angles

### Delivery

- Cardboard box



|  | Jaw length<br>mm | Cross-section<br>mm | Order no. | List price<br>EUR |
|--|------------------|---------------------|-----------|-------------------|
|  | 200              | 20 x 8              | 0396 432  | 11.10             |
|  | 250              | 25 x 8              | 0396 433  | 13.70             |
|  | 300              | 25 x 8              | 0396 434  | 16.70             |
|  | 400              | 25 x 8              | 0396 435  | 21.50             |
|  | 500              | 25 x 8              | 0396 436  | 23.90             |



## 0003 Wooden cases for squares



|  | Jaw length<br>mm | Internal dimensions<br>L x W x H<br>mm | Order no. | List price<br>EUR |
|---|------------------|--|-----------|-------------------|
| <b>For squares with base</b>  |                  |  |           |                   |
|   | 150 x 100        | 160 x 105 x 27                         | 0003 284  | 7.70              |
|   | 200 x 130        | 210 x 135 x 34                         | 0003 286  | 10.20             |
|   | 250 x 165        | 260 x 170 x 38                         | 0003 288  | 21.80             |
|   | 300 x 200        | 312 x 205 x 42                         | 0003 290  | 21.80             |
|   | 400 x 265        | 412 x 270 x 48                         | 0003 292  | 41.50             |
|   | 500 x 330        | 512 x 335 x 54                         | 0003 294  | 46.80             |
| <b>For flat type squares</b>  |                  |  |           |                   |
|   | 150 x 100        | 160 x 105 x 22                         | 0003 283  | 6.90              |
|   | 200 x 130        | 210 x 135 x 27                         | 0003 285  | 8.70              |
|   | 250 x 165        | 260 x 170 x 27                         | 0003 287  | 9.60              |
|   | 300 x 200        | 312 x 205 x 27                         | 0003 289  | 13.10             |
|   | 400 x 265        | 412 x 270 x 27                         | 0003 291  | 37.60             |
|   | 500 x 330        | 512 x 335 x 27                         | 0003 293  | 41.90             |
| <b>For squares with and without base</b>  |                  |  |           |                   |
|   | 50 x 40          | 55 x 45 x 22                           | 0003 280  | 4.90              |
|   | 75 x 50          | 80 x 55 x 22                           | 0003 281  | 5.30              |
|   | 100 x 70         | 105 x 75 x 22                          | 0003 282  | 5.60              |



## 0411 Protractors

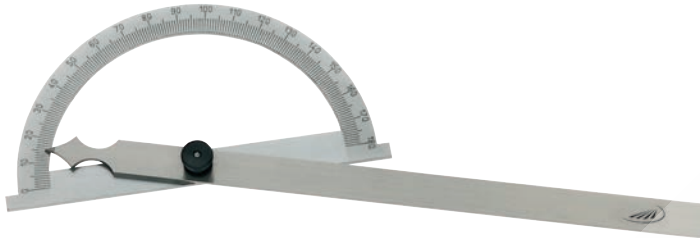

### Model

- Locking screw
- High precision, laser graduated degree scale
- Factory standard
- 0 - 180°

### Delivery

- Cardboard box

| ☒   | ☒ | Jaw length | Graduated arc dia. | Order no. | List price |
|---|---|------------|--------------------|-----------|------------|
|   |   | mm         | mm                 |           |            |
| <b>Special steel, satin chrome finished graduated arc</b> |   |            |                    |           |            |
|   |   | 120        | 80                 | 0411 301  | 28.30      |
|   |   | 150        | 120                | 0411 302  | 36.50      |
|   |   | 200        | 150                | 0411 303  | 40.50      |
|   |   | 300        | 200                | 0411 304  | 59.00      |
|   |   | 500        | 300                | 0411 305  | 117.00     |
|   |   | 600        | 300                | 0411 306  | 147.00     |
|   |   | 800        | 300                | 0411 307  | 159.00     |
|   |   | 600        | 400                | 0411 308  | 166.00     |
|   |   | 800        | 400                | 0411 309  | 175.00     |
|   |   | 1000       | 400                | 0411 310  | 216.00     |

## 0412 Protractors

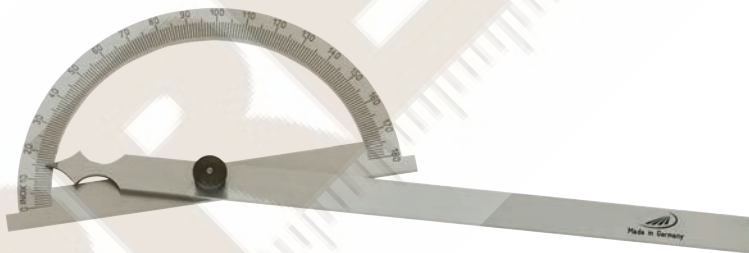

### Model

- Locking screw
- Stainless steel
- Factory standard
- 0 - 180°
- High precision, laser graduated degree scale

### Delivery

- Cardboard box

| ☒ | ☒ | Jaw length | Graduated arc dia. | Order no. | List price |
|---|---|------------|--------------------|-----------|------------|
|   |   | mm         | mm                 |           |            |
|   |   | 120        | 80                 | 0412 201  | 39.90      |
|   |   | 150        | 120                | 0412 202  | 43.20      |
|   |   | 200        | 150                | 0412 203  | 44.50      |
|   |   | 300        | 200                | 0412 204  | 62.00      |



## 0413 Protractors

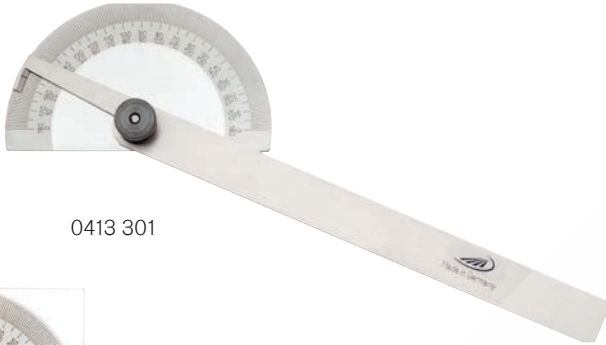

0413 301

### Model

- Locking screw
- Special steel
- Factory standard
- 0 - 180°
- High precision, laser graduated degree scale
- Graduated in opposite directions
- Satin chrome finished

### Delivery

- Cardboard box



0413 302

|  | ✂ | 📏 | Dimensions | Jaw length | Order no. | List price |
|--|---|---|------------|------------|-----------|------------|
|  |   |   | mm         | mm         |           | EUR        |
|  |   |   | Ø 85       | 150        | 0413 301  | 27.00      |
|  |   |   | 85 x 50    | 150        | 0413 302  | 28.10      |

## 0415 Bevel protractors

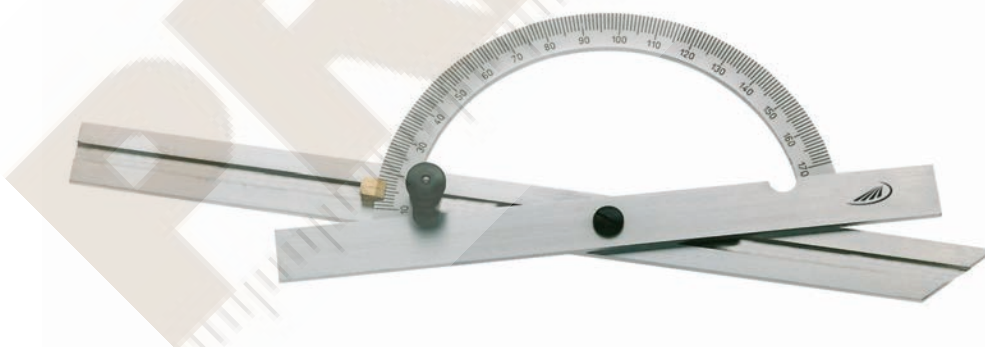

### Model

- Locking screw
- Special steel, pointer arm is satin chrome finished
- Factory standard
- Adjustable stop bar 10° - 170°
- High precision, laser graduated degree scale

### Delivery

- Cardboard box

|  | ✂ | 📏 | Jaw length | Graduated arc dia. | Order no. | List price |
|--|---|---|------------|--------------------|-----------|------------|
|  |   |   | mm         | mm                 |           | EUR        |
|  |   |   | 150        | 100                | 0415 301  | 74.00      |
|  |   |   | 300        | 150                | 0415 302  | 114.00     |
|  |   |   | 400        | 200                | 0415 303  | 155.00     |
|  |   |   | 500        | 250                | 0415 304  | 212.00     |
|  |   |   | 600        | 300                | 0415 305  | 241.00     |



## 0416 Bevel protractors with double stop rail



### Model

- Locking screw
- Special steel, pointer arm is satin chrome finished
- Factory standard
- Adjustable stop bar  
10° - 170°
- High precision, laser graduated degree scale
- Two-way adjustable stop bar

### Delivery

- Cardboard box

|  |  |  | Jaw length | Graduated arc dia. | Order no. | List price |
|--|--|--|------------|--------------------|-----------|------------|
|  |  |  | mm         | mm                 |           | EUR        |
|  |  |  | 150        | 100                | 0416 301  | 147.00     |
|  |  |  | 300        | 150                | 0416 302  | 192.00     |
|  |  |  | 400        | 200                | 0416 303  | 248.00     |
|  |  |  | 500        | 250                | 0416 304  | 411.00     |
|  |  |  | 600        | 300                | 0416 305  | 476.00     |



## 0425 DIGI-MET® Universal bevel protractors



### Model

- Clamping unit
- Stainless steel
- Factory standard
- Reversible measuring range:
  - 1 x 360°
  - 2 x 180°
  - 4 x 90°
- Reversible indication
  - degree and minutes
  - decimal degree

### Functions

- ON / OFF
- Set to zero at any point
- Data output Opto RS 232

### Delivery

- Wooden case

| ✕ | ✕ | Blade length<br>mm | Reading<br>mm | Order no. | List price<br>EUR |
|---|---|--------------------|---------------|-----------|-------------------|
|   |   | 150                | 0.01° or 1'   | 0425 701  | 1486.00           |
|   |   | 200                | 0.01° or 1'   | 0425 702  | 1501.00           |
|   |   | 300                | 0.01° or 1'   | 0425 703  | 1513.00           |

### Accessories



0996701

0996705

| Accessories              | Order no. | List price<br>EUR |
|--------------------------|-----------|-------------------|
| data cable opto to RS232 | 0996 701  | 87.00             |
| data cable opto to USB   | 0996 705  | 166.00            |



## 0420 Universal level protractors



### Model

- Locking screw
- Stainless steel
- Factory standard
- Vernier scale reading 5 minutes

### Delivery

- Cardboard box

|  | Measuring range<br>in ° | Blade length<br>mm | Order no. | List price<br>EUR |
|--|-------------------------|--------------------|-----------|-------------------|
|  | 4 x 90 °                | 150 / 200 / 300    | 0420 522  | 89.00             |

### Accessories

|                              | Order no. | List price<br>EUR |
|------------------------------|-----------|-------------------|
| Replacement magnifying lense | 0420 121  | 18.40             |
| Replacement blade 150 mm     | 0420 206  | 20.80             |
| Replacement blade 200 mm     | 0420 207  | 21.80             |
| Replacement blade 300 mm     | 0420 208  | 22.00             |



0420121



0420122



0420124



0420206