



## FLANGE MOUNTED TRANSDUCERS (FMT)

Calibration details



Flange Mounted Transducers (FMT) incorporate mounting points for securely fixing the transducer to the working surface. The transducer lead which comes attached to the transducer, is fitted with a high quality connector, suitable for attachment to TST, TTT and T-Box™ 2 instruments. FMTs are provided with precision square drive adaptors suitable for the calibration of torque wrenches.



FMT 2 N-m

4	FMT
50671.xxx*	0.04 - 2 N·m, ¼" sq. dr. with Joint Simulator
50672.xxx	0.5 - 10 N·m, ¼" sq. dr. with Joint Simulator
50673.xxx	1.25 - 25 N·m, ¼" + ⅜" sq. dr. with Joint Simulator
50677.xxx*	0.4 - 20 lbf-in, ¼" sq. dr. with Joint Simulator
50678.xxx	5 - 100 lbf-in, ¼" sq. dr. with Joint Simulator
50679.xxx	12.5 - 250 lbf-in, ¼" + ⅜" sq. dr. with Joint Simulator



FMT 150 N-m

4	FMT
50844.xxx	3 - 60 N·m, ½" + ⅜" sq. dr. with Joint Simulator
50674.xxx	7.5 - 150 N·m, ½" + ⅜" sq. dr. with Joint Simulator
50680.xxx	5 - 100 lbf-ft, ½" + ⅜" sq. dr. with Joint Simulator
50675.xxx	20 - 400 N·m, ½" + ¾" sq. dr.
50681.xxx	12.5 - 250 lbf-ft, ½" + ¾" sq. dr.



Model	FMT (2 N·m - 25 N·m)	FMT (60 N·m - 400 N·m)	FMT (1,500 N·m)	
Part Number	50671.xxx 50672.xxx 50673.xxx 50677.xxx 50678.xxx 50679.xxx	50844.xxx 50674.xxx 50680.xxx 50675.xxx 50681.xxx	50676.xxx 50682.xxx	
Dimensions (mm)	ØA	5.5	8.5	
	ØB	64	90	
	C	63	65	
	D	83 (⅜"), 86 (⅝")	92 (⅜"), 95 (⅝"), 101 (½")	128 (½"), 138 (¾"), 138 (1")
	E	132	192 (60 N·m, 150 N·m & 100 lbf-ft) N/A (400 N·m & 250 lbf-ft)	N/A
Weight (kg)	0.8 (2 N·m & 20 lbf-in) 0.8 (10 N·m & 100 lbf-in) 0.9 (25 N·m & 250 lbf-in)	3.3 (60 N·m, 150 N·m & 100 lbf-ft) 1.5 (400 N·m) 2.7 (250 lbf-ft)	7.0	

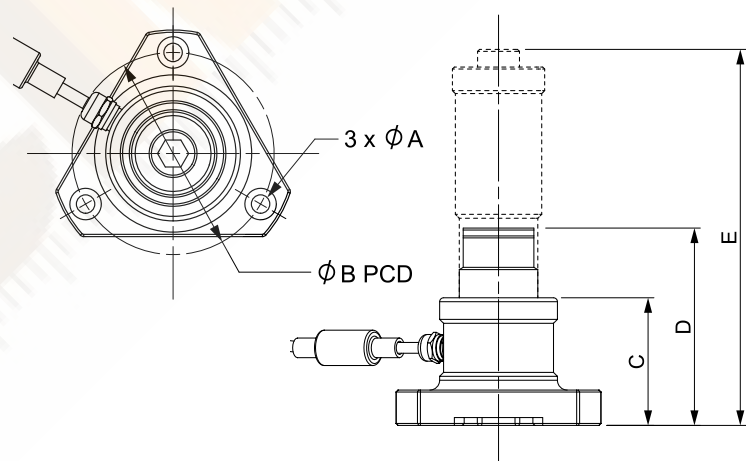

4	FMT (Ancillary Section)
50539	3 N·m Joint Simulator (also fits TST & TruCheck 2)
50540	10 N·m Joint Simulator (also fits TST & TruCheck 2)
50541	25 N·m Joint Simulator (also fits TST)
50852	30 N·m Joint Simulator (also fits TruCheck 2)
50845	60 N·m Joint Simulator
50692	150 N·m Joint Simulator
50819	400 N·m Joint Simulator
52236	¼" Hexagon - ¼" Square Drive Adaptor
52237	¼" Hexagon - ⅜" Square Drive Adaptor
52251	⅜" Female Square - 22 mm Bi-Square Adaptor
52246	½" Female Square - 22 mm Bi-Square Adaptor
52245	¾" Female Square - 22 mm Bi-Square Adaptor
52254	½" Female Square - 35 mm Bi-Square Adaptor
52241	¾" Female Square - 35 mm Bi-Square Adaptor
52242	1" Female Square - 35 mm Bi-Square Adaptor

4	FMT Mounting Brackets
62221.BLK9005	FMT Mounting Bracket 2 - 400 N·m
62220.BLK9005	FMT Mounting Bracket 150 - 1,500 N·m