



PNEUTORQUE® STANDARD SERIES



From left to right PT 5 Remote, PT 5 Single Speed, PT 5 Automatic Two Speed and PT 5 Manual Two Speed

Based on the original PneuTorque®, the ‘Standard Series’ range is a direct result of over 50 years of refinement and development necessary to keep pace with the requirements of industry today.

In use in many thousands of applications worldwide PneuTorque® wrenches continue to represent the foundation of Norbar’s powered tool range. Two speed models offer all the advantages of single speed versions but with the additional benefit of a run-down speed five times greater than the high torque speed setting.

- Models available for almost every bolting and torque application, up to 300,000 N·m.
Models above 6,000 N·m are Manufactured to Order, for more information please contact Norbar
- Forward and reverse operation
- Quiet : Noise level : 81dB(A), with an uncertainty K = 3dB, when free running
- Vibration : Does not exceed 2.5m/s² (highest measured under test: 0.444m/s²)
- Stall control gives repeatability of ±5% on a given joint
- Other reaction styles can be designed to suit specific applications
- Electronic torque transducers can be fitted for precise torque monitoring

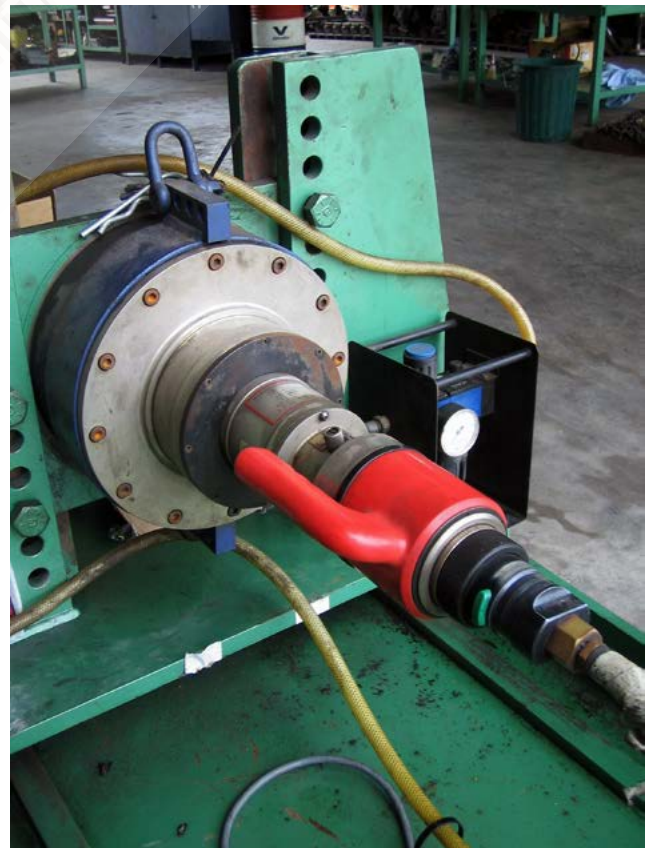



PNEUTORQUE® STANDARD SERIES



11	TO 100,000 N·m - SINGLE SPEED
16031	PT 1 ¾" sq. dr., 160 - 680 N·m, 120 - 500 lbf-ft
16011	PT 1 1" sq. dr., 160 - 680 N·m, 120 - 500 lbf-ft
16098	PT 1A ¾" sq. dr., 270 - 1,200 N·m, 200 - 900 lbf-ft
16097	PT 1A 1" sq. dr., 270 - 1,200 N·m, 200 - 900 lbf-ft
16013	PT 2 1" sq. dr., 515 - 1,700 N·m, 380 - 1,250 lbf-ft
16015	PT 5 1" sq. dr., 880 - 3,400 N·m, 650 - 2,500 lbf-ft
16017	PT 6 1½" sq. dr., 880 - 3,400 N·m, 650 - 2,500 lbf-ft
16066	PT 7 1½" sq. dr., 1,762 - 6,000 N·m, 1,300 - 4,500 lbf-ft
16072	PT 9 1½" sq. dr., 2,710 - 9,500 N·m, 2,000 - 7,000 lbf-ft
16046	PT 11 2½" sq. dr., 4,400 - 20,000 N·m, 3,250 - 14,700 lbf-ft
18086	PT 12 2½" sq. dr., 9,500 - 34,000 N·m, 7,000 - 25,000 lbf-ft
16052	PT 13 2½" sq. dr., 13,550 - 47,000 N·m, 10,000 - 35,000 lbf-ft
16045	PT 14 3½" sq. dr., 22,375 - 100,000 N·m, 16,500 - 73,500 lbf-ft

11	TO 9,500 N·m - AUTOMATIC TWO SPEED
16031.AUT	PT 1 ¾" sq. dr., Auto 2SP 160 - 680 N·m, 120 - 500 lbf-ft
16011.AUT	PT 1 1" sq. dr., Auto 2SP 160 - 680 N·m, 120 - 500 lbf-ft
16098.AUT	PT 1A ¾" sq. dr., Auto 2SP 400 - 1,200 N·m, 295 - 900 lbf-ft
16097.AUT	PT 1A 1" sq. dr., Auto 2SP 400 - 1,200 N·m, 295 - 900 lbf-ft
16013.AUT	PT 2 1" sq. dr., Auto 2SP 700 - 1,700 N·m, 516 - 1,250 lbf-ft
16015.AUT	PT 5 1" sq. dr., Auto 2SP 880 - 3,400 N·m, 650 - 2,500 lbf-ft
16017.AUT	PT 6 1½" sq. dr., Auto 2SP 880 - 3,400 N·m, 650 - 2,500 lbf-ft
16066.AUT	PT 7 1½" sq. dr., Auto 2SP 2,200 - 6,000 N·m, 1,622 - 4,500 lbf-ft
16072.AUT	PT 9 1½" sq. dr., Auto 2SP 2,100 - 9,500 N·m, 2,286 - 7,000 lbf-ft

MTS = Manual Two Speed. Auto 2SP = Automatic Two Speed.

Angle Encoders are available for Standard Series PTs please contact Norbar for further details.

NB: PneuTorque® PT 11 - PT 18 are supplied with a Lubro Control Unit as standard equipment. PneuTorques PT 12, 13 and 14 are also supplied with a weld prepared reaction ring as standard. PT 13 and 14 are also supplied with a transporting trolley. PT 15 - 18 do not include output drive or reaction. These components will be engineered uniquely for each application. Remote PT part numbers are designated with an .X

e.g. PT 1 Remote is 16031.X

e.g. PT 1 Remote Auto is 16031.XAUT

For remote models, consult Norbar for prices.



11	TO 300,000 N·m - MANUAL TWO SPEED
16031.MTS	PT 1 ¾" sq. dr., MTS 160 - 680 N·m, 120 - 500 lbf-ft
16011.MTS	PT 1 1" sq. dr., MTS 160 - 680 N·m, 120 - 500 lbf-ft
16098.MTS	PT 1A ¾" sq. dr., MTS 270 - 1,200 N·m, 200 - 900 lbf-ft
16097.MTS	PT 1A 1" sq. dr., MTS 270 - 1,200 N·m, 200 - 900 lbf-ft
16013.MTS	PT 2 1" sq. dr., MTS 515 - 1,700 N·m, 380 - 1,250 lbf-ft
16015.MTS	PT 5 1" sq. dr., MTS 880 - 3,400 N·m, 650 - 2,500 lbf-ft
16017.MTS	PT 6 1½" sq. dr., MTS 880 - 3,400 N·m, 650 - 2,500 lbf-ft
16066.MTS	PT 7 1½" sq. dr., 1,762 - 6,000 N·m, 1,300 - 4,500 lbf-ft
16072.MTS	PT 9 1½" sq. dr., 2,710 - 9,500 N·m, 2,000 - 7,000 lbf-ft
16046.MTS	PT 11 2½" sq. dr., 4,400 - 20,000 N·m, 3,250 - 14,700 lbf-ft
18086.MTS	PT 12 2½" sq. dr., 9,500 - 34,000 N·m, 7,000 - 25,000 lbf-ft
16052.MTS	PT 13 2½" sq. dr. 13,550 - 47,000 N·m, 10,000 - 35,000 lbf-ft
16045.MTS	PT 14 3½" sq. dr. 22,375 - 100,000 N·m, 16,500 - 73,500 lbf-ft
18089.MTS	PT 15 MTS 40,000 - 150,000 N·m, 29,500 - 110,500 lbf-ft
18090.MTS	PT 16 MTS 55,000 - 200,000 N·m, 40,500 - 147,500 lbf-ft
18088.MTS	PT 17 MTS 70,000 - 250,000 N·m, 51,500 - 184,500 lbf-ft
16054.MTS	PT 18 MTS 85,000 - 300,000 N·m, 62,500 - 221,500 lbf-ft
16490	Lifting Bracket for Standard Series (up to PT7)

PT 9 and larger models are available as Manufacture to Order, please contact Norbar for more details





PNEUTORQUE® STANDARD SERIES



PneuTorque® Standard Series Manual Two Speed

Model	PT 1	PT 1A	PT 2	PT 5	PT 6	PT 7	PT 9	PT 11	PT 12	PT 13	PT 14	PT 15	PT 16	PT 17	PT 18	
Part Number	16031.MTS 16011.MTS	16098.MTS 16097.MTS	16013.MTS	16015.MTS	16017.MTS	16066.MTS	16072.MTS	16046.MTS	18086.MTS	16052.MTS	16045.MTS	18089.MTS	18090.MTS	18088.MTS	16054.MTS	
Output Speed (rpm)	150	75	45	25	25	12.5	9	6	2.5	1.5	1	0.5	0.4	0.35	0.3	
Dimensions (mm)	∅D	108	108	108	119	119	144	184	212	248	315	315	*	410	410	520
	H	436	436	436	479	481	509	504	581	622	664	729	*	866	939	936
	L	303	303	303	355	355	423	448	609	325	341	341	*	N/A	N/A	N/A
	R1	N/A	N/A	N/A	N/A	N/A	84	84	N/A	N/A	N/A	N/A	N/A	N/A	N/A	N/A
	R2 min.	83	83	83	86	86	150	175	320	N/A	N/A	N/A	N/A	N/A	N/A	N/A
	R2 max.	216	216	216	263	263	331	351	500	N/A	N/A	N/A	N/A	N/A	N/A	N/A
Tool Weight (kg)	14.1	14.6	14.6	17.5	17.5	23.2	27.9	42.1	53.3	105.7	122.9	*	270.0	285.0	380.0	
Reaction Weight (kg)	2.2	2.2	2.2	2.5	2.5	6.3	8.3	13.3	6.5	6.9	10.4	N/A	N/A	N/A	N/A	

PneuTorque® Standard Series Single Speed

Model	PT 1	PT 1A	PT 2	PT 5	PT 6	PT 7	PT 9	PT 11	PT 12	PT 13	PT 14	
Part Number	16031 16011	16098 16097	16013	16015	16017	16066	16072	16046	18086	16052	16045	
Output Speed (rpm)	30	15	9	5	5	2.5	1.8	1.2	0.5	0.3	0.2	
Dimensions (mm)	∅D	108	108	108	119	119	144	184	212	248	315	315
	H	350	350	350	393	395	423	418	495	536	578	643
	L	303	303	303	355	355	423	448	609	325	341	341
	R1	N/A	N/A	N/A	N/A	N/A	84	84	N/A	N/A	N/A	N/A
	R2 min.	83	83	83	86	86	150	175	320	N/A	N/A	N/A
	R2 max.	216	216	216	263	263	331	351	500	N/A	N/A	N/A
Tool Weight (kg)	10.6	11.1	11.1	14.0	14.0	19.7	24.4	38.6	49.8	102.2	119.4	
Reaction Weight (kg)	2.2	2.2	2.2	2.5	2.5	6.3	8.3	13.3	6.5	6.9	10.4	

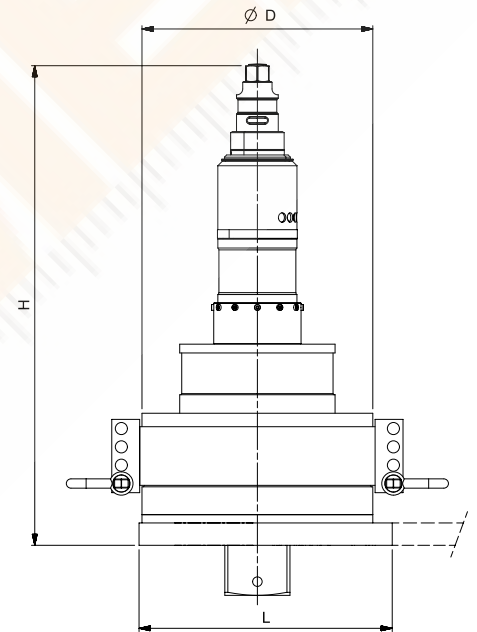

PneuTorque® Standard Series Automatic Two Speed

Model	PT 1	PT 1A	PT 2	PT 5	PT 6	PT 7	PT 9	
Part Number	16031.AUT 16011.AUT	16098.AUT 16097.AUT	16013.AUT	16015.AUT	16017.AUT	16066.AUT	16072.AUT	
Output Speed (rpm)	150	75	45	25	25	12.5	9	
Dimensions (mm)	∅D	108	108	108	119	119	144	184
	H	419	419	419	462	464	492	487
	L	303	303	303	355	355	423	448
	R1	N/A	N/A	N/A	N/A	N/A	84	84
	R2 min.	83	83	83	86	86	150	175
	R2 max.	216	216	216	263	263	331	351
Tool Weight (kg)	14.1	14.6	14.6	17.5	17.5	23.2	27.9	
Reaction Weight (kg)	2.2	2.2	2.2	2.5	2.5	6.3	8.3	

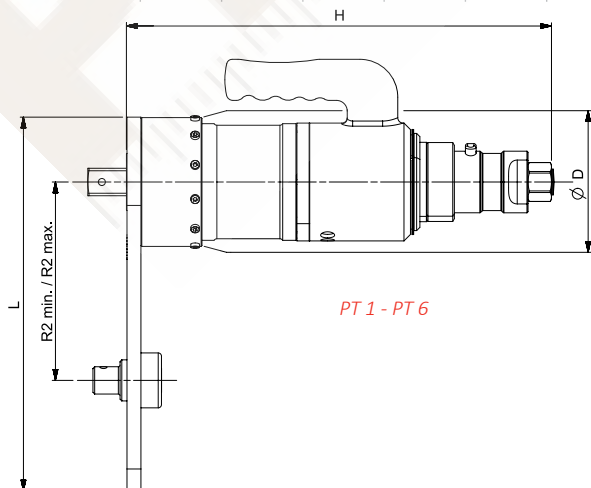

PT 1 - PT 6

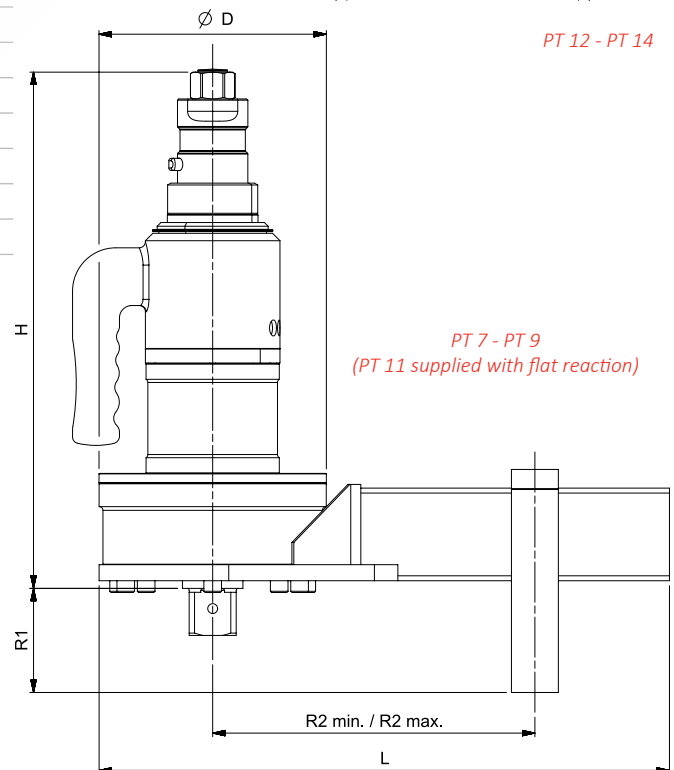

PT 12 - PT 14

PT 7 - PT 9
(PT 11 supplied with flat reaction)



PNEUTORQUE® STANDARD SERIES

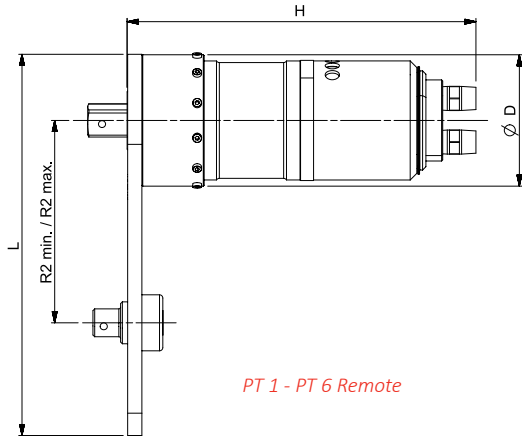

PneuTorque® Standard Series Automatic Two Speed - Remote

Model	PT 1	PT 1A	PT 2	PT 5	PT 6	PT 7	PT 9
Part Number	16031.XAUT 16011.XAUT	16098.XAUT 16097.XAUT	16013.XAUT	16015.XAUT	16017.XAUT	16066.XAUT	16072.XAUT
Output Speed (rpm)	150	75	45	25	25	12.5	9
Dimensions (mm)	ØD	108	108	108	119	119	144
	H	339	339	339	382	383	412
	L	303	303	303	355	355	423
	R1	N/A	N/A	N/A	N/A	N/A	84
	R2 min.	83	83	83	86	86	150
	R2 max.	216	216	216	263	263	331
Tool Weight (kg)	14.1	14.6	14.6	17.5	17.5	23.2	27.9
Reaction Weight (kg)	2.2	2.2	2.2	2.5	2.5	6.3	8.3

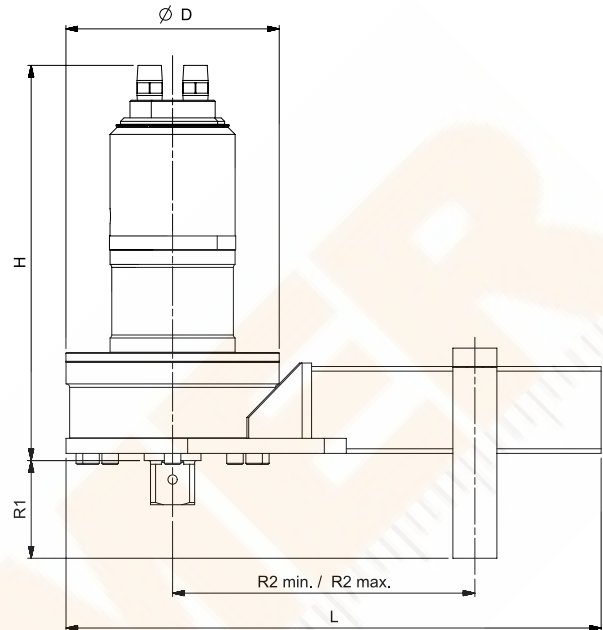

PneuTorque® Standard Series Single Speed - Remote

Model	PT 1	PT 1A	PT 2	PT 5	PT 7	PT 9	PT 11	PT 12	PT 13	PT 14
Part Number	16031.X 16011.X	16098.X 16097.X	16013.X	16015.X	16066.X	16072.X	16046.X	18086.X	16052.X	16045.X
Output Speed (rpm)	30	15	9	5	2.5	1.8	1.2	0.5	0.3	0.2
Dimensions (mm)	ØD	108	108	108	119	144	184	212	248	315
	H	270	270	270	313	343	340	415	456	490
	L	303	303	303	355	423	448	609	325	341
	R1	N/A	N/A	N/A	N/A	84	84	N/A	N/A	N/A
	R2 min.	83	83	83	86	150	175	320	N/A	N/A
	R2 max.	216	216	216	263	331	351	500	N/A	N/A
Tool Weight (kg)	10.6	11.1	11.1	14.0	17.9	24.4	38.6	49.8	102.2	119.4
Reaction Weight (kg)	2.2	2.2	2.2	2.5	6.3	8.3	13.3	6.5	6.9	10.4

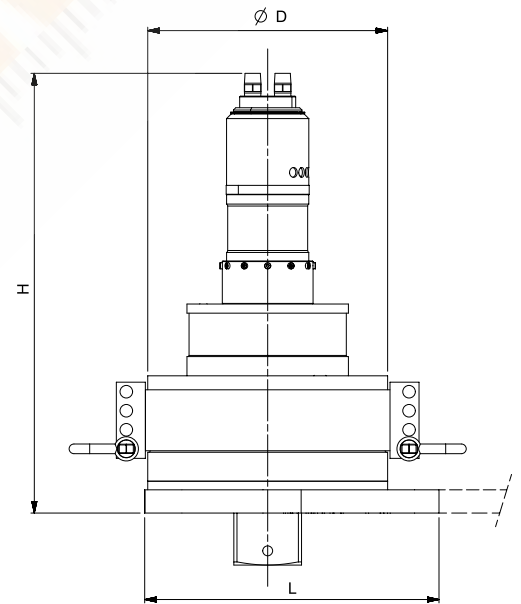

PneuTorque® Standard Series Manual Two Speed - Remote

Model	PT 1	PT 1A	PT 2	PT 5	PT 6	PT 7	PT 9	PT 11	PT 12	PT 13	PT 14	PT 15	PT 16	PT 17	PT 18	
Part Number	16031.XMSTS 16011.XMSTS	16098.XMSTS 16097.XMSTS	16013.XMSTS	16015.XMSTS	16017.XMSTS	16066.XMSTS	16072.XMSTS	16046.XMSTS	18086.XMSTS	16052.XMSTS	16045.XMSTS	18089.XMSTS	18090.XMSTS	18088.XMSTS	16054.XMSTS	
Output Speed (rpm)	150	75	45	25	25	12.5	9	6	2.5	1.5	1	0.5	0.4	0.35	0.3	
Dimensions (mm)	ØD	108	108	108	119	119	144	184	212	248	315	315	*	410	410	520
	H	356	356	356	399	400	429	425	501	542	576	649	*	786	859	856
	L	303	303	303	355	355	423	448	609	325	341	341	*	N/A	N/A	N/A
	R1	N/A	N/A	N/A	N/A	N/A	84	84	N/A	N/A	N/A	N/A	N/A	N/A	N/A	N/A
	R2 min.	83	83	83	86	86	150	175	320	N/A	N/A	N/A	N/A	N/A	N/A	N/A
	R2 max.	216	216	216	263	263	331	351	500	N/A	N/A	N/A	N/A	N/A	N/A	N/A
Tool Weight (kg)	14.1	14.6	14.6	17.5	17.5	23.2	27.9	42.1	53.3	105.7	122.9	*	270.0	285.0	380.0	
Reaction Weight (kg)	2.2	2.2	2.2	2.5	2.5	6.3	8.3	13.3	6.5	6.9	10.4	N/A	N/A	N/A	N/A	

* Available on request