



PROFESSIONAL TORQUE WRENCHES



Since its original, award winning launch in 1984, Norbar's Professional torque wrench range has become one of the most popular wrench ranges available worldwide. In this re-engineered version, the core principles of accuracy, durability and comfort are carried over but almost every component part is new and improved.

- Accurate to $\pm 3\%$ of reading which meets the requirements of ISO 6789-2:2017
- Supplied with a traceable 'Calibration Certificate' allowing end users to adhere to more stringent quality control processes
- Large scale for better visibility and more accurate setting
- Fast scale adjustment reducing the effort required to adjust
- If you adjust your wrench regularly, you can do more work



• Imperial scale only models available, contact Norbar



Pro 15 & 25
Automotive Ratchets



Unlocked



Locked



Female Torque Handle



16 mm Spigot End

Compared with other torque wrenches:

Norbar's 'harmonic drive' scale provides a long scale length for good resolution and accurate setting in both scale units. By contrast, micrometer type scales allow accurate setting in the primary scale unit but relatively poor accuracy of setting in the secondary units because of limited resolution. The Professional wrench is amongst the easiest wrenches on the market to accurately set.



PROFESSIONAL TORQUE WRENCHES



There will be a phased change to the 'Industrial Ratchet' on our Professional range of torque wrenches. Norbar will be moving from the 'Mushroom' square drive to a captive 'push-through' square drive

2 INDUSTRIAL RATCHET - DUAL SCALE

15002 [†]	Pro 50, 3/8", 10 - 50 N·m, 7.5 - 37.5 lbf·ft
15003 [†]	Pro 100, 1/2", 20 - 100 N·m, 15 - 75 lbf·ft
15004	Pro 200, 1/2", 40 - 200 N·m, 30 - 150 lbf·ft
15005	Pro 300, 1/2", 60 - 300 N·m, 44 - 222 lbf·ft
15006	Pro 340, 1/2", 60 - 340 N·m, 44 - 250 lbf·ft
15007*	Pro 400, 3/4", 80 - 400 N·m, 60 - 300 lbf·ft

2 INDUSTRIAL RATCHET - N·m ONLY

15042 [†]	Pro 50, 3/8", 10 - 50 N·m
15043 [†]	Pro 100, 1/2", 20 - 100 N·m
15044	Pro 200, 1/2", 40 - 200 N·m
15045	Pro 300, 1/2", 60 - 300 N·m
15046	Pro 340, 1/2", 60 - 340 N·m
15047*	Pro 400, 3/4", 80 - 400 N·m

2 INDUSTRIAL RATCHET - lbf·ft ONLY

15172 [†]	Pro 50, 3/8", 7.5 - 37.5 lbf·ft
15173 [†]	Pro 100, 1/2", 15 - 75 lbf·ft
15174	Pro 200, 1/2", 30 - 150 lbf·ft
15175	Pro 300, 1/2", 44 - 220 lbf·ft
15176	Pro 340, 1/2", 45 - 250 lbf·ft
15177*	Pro 400, 3/4", 60 - 300 lbf·ft

[†] Supplied with 1/2" sq. dr. adaptor

[†] Supplied with 3/8" sq. dr. adaptor

* Model 400 supplied with a Stepped Square

2 AUTOMOTIVE RATCHET (Reversible) - DUAL SCALE

15220	Pro 15, 1/4", 3 - 15 N·m, 27 - 132 lbf·in
15221	Pro 15, 3/8", 3 - 15 N·m, 27 - 132 lbf·in
15222	Pro 25, 1/4", 5 - 25 N·m, 44 - 220 lbf·in
15223	Pro 25, 3/8", 5 - 25 N·m, 44 - 220 lbf·in
15012	Pro 50, 3/8", 10 - 50 N·m, 7.5 - 37.5 lbf·ft
15013	Pro 50, 1/2", 10 - 50 N·m, 7.5 - 37.5 lbf·ft
15014	Pro 100, 3/8", 20 - 100 N·m, 15 - 75 lbf·ft
15015	Pro 100, 1/2", 20 - 100 N·m, 15 - 75 lbf·ft
15016	Pro 200, 1/2", 40 - 200 N·m, 30 - 150 lbf·ft

2 AUTOMOTIVE RATCHET (Reversible) - N·m ONLY

15224	Pro 15, 1/4", 3 - 15 N·m
15225	Pro 15, 3/8", 3 - 15 N·m
15226	Pro 25, 1/4", 5 - 25 N·m
15227	Pro 25, 3/8", 5 - 25 N·m
15022	Pro 50, 3/8", 10 - 50 N·m
15023	Pro 50, 1/2", 10 - 50 N·m
15024	Pro 100, 3/8", 20 - 100 N·m
15025	Pro 100, 1/2", 20 - 100 N·m
15026	Pro 200, 1/2", 40 - 200 N·m





PROFESSIONAL TORQUE WRENCHES



2	TORQUE HANDLE ADJUSTABLE 16 mm SPIGOT - DUAL SCALE
15060	Pro 15, 16 mm spigot, 3 - 15 N·m, 27 - 132 lbf·in
15061	Pro 25, 16 mm spigot, 5 - 25 N·m, 44 - 220 lbf·in
15062	Pro 50, 16 mm spigot, 10 - 50 N·m, 7.5 - 37.5 lbf·ft
15063	Pro 100, 16 mm spigot, 20 - 100 N·m, 15 - 75 lbf·ft
15064	Pro 200, 16 mm spigot, 40 - 200 N·m, 30 - 150 lbf·ft
15065	Pro 300, 16 mm spigot, 60 - 300 N·m, 44 - 222 lbf·ft

2	TORQUE HANDLE ADJUSTABLE 16 mm SPIGOT - N·m ONLY
15070	Pro 15, 16 mm spigot, 3 - 15 N·m
15071	Pro 25, 16 mm spigot, 5 - 25 N·m
15072	Pro 50, 16 mm spigot, 10 - 50 N·m
15073	Pro 100, 16 mm spigot, 20 - 100 N·m
15074	Pro 200, 16 mm spigot, 40 - 200 N·m
15075	Pro 300, 16 mm spigot, 60 - 300 N·m



2	FEMALE TORQUE HANDLE ADJUSTABLE - DUAL SCALE
15100	Pro 15, 9 x 12 mm, 3 - 15 N·m, 27 - 132 lbf·in
15101	Pro 25, 9 x 12 mm, 5 - 25 N·m, 44 - 220 lbf·in
15102	Pro 50, 9 x 12 mm, 10 - 50 N·m, 7.5 - 37.5 lbf·ft
15103	Pro 100, 9 x 12 mm, 20 - 100 N·m, 15 - 75 lbf·ft
15104	Pro 200, 9 x 12 mm, 40 - 200 N·m, 30 - 150 lbf·ft
15105	Pro 200, 14 x 18 mm, 40 - 200 N·m, 30 - 150 lbf·ft
15106	Pro 300, 14 x 18 mm, 60 - 300 N·m, 44 - 222 lbf·ft
15107	Pro 340, 14 x 18 mm, 60 - 340 N·m, 44 - 250 lbf·ft
15108	Pro 400, 14 x 18 mm, 80 - 400 N·m, 60 - 300 lbf·ft

2	FEMALE TORQUE HANDLE ADJUSTABLE - N·m ONLY
15110	Pro 15, 9 x 12 mm, 3 - 15 N·m
15111	Pro 25, 9 x 12 mm, 5 - 25 N·m
15112	Pro 50, 9 x 12 mm, 10 - 50 N·m
15113	Pro 100, 9 x 12 mm, 20 - 100 N·m
15114	Pro 200, 9 x 12 mm, 40 - 200 N·m
15115	Pro 200, 14 x 18 mm, 40 - 200 N·m
15116	Pro 300, 14 x 18 mm, 60 - 300 N·m
15117	Pro 340, 14 x 18 mm, 60 - 340 N·m
15118	Pro 400, 14 x 18 mm, 80 - 400 N·m



Pro 25 Torque Handle



Pro 25 Female Torque Handle



PROFESSIONAL TORQUE WRENCHES



Industrial Ratchet

Model	Pro 50	Pro 100	Pro 200	Pro 300	Pro 340	Pro 400	
Part Number	15002 15042 15172	15003 15043 15173	15004 15044 15174	15005 15045 15175	15006 15046 15176	15007 15047 15177	
Dimensions (mm)	A	335	387	470	593	685	686
	B	317	364	447	567	659	661
	C	231	278	361	480	572	574
	∅D	35	45	45	52	52	51
	E	37	48	48	48	48	47
	F	26	32	32	33	33	24
Weight (kg)	0.7	0.9	1.1	1.4	1.5	1.9	

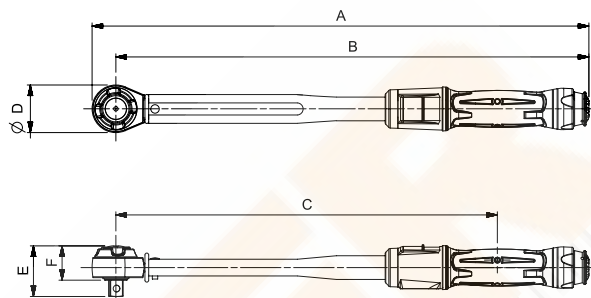

Automotive Ratchet

Model	Pro 15 Pro 25	Pro 50 3/8"	Pro 50 1/2"	Pro 100 3/8"	Pro 100 1/2"	Pro 200	
Part Number	15220, 15221, 15222, 15223, 15224, 15225, 15226, 15227	15012 15022	15013 15023	15014 15024	15015 15025	15016 15026	
Dimensions (mm)	A	221	327	327	367	367	465
	B	209	312	312	352	352	444
	C	140	226	226	266	266	358
	∅D	25	30	30	30	30	43
	E	25	33	38	33	38	46
	F	18	22	22	22	22	30
Weight (kg)	0.3	0.7	0.7	0.8	0.8	1.0	

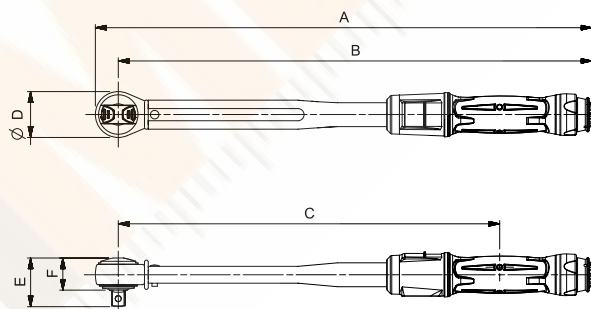

Spigot Torque Handle

Model	Pro 15 Pro 25	Pro 50	Pro 100	Pro 200	Pro 300	
Part Number	15060 15061 15070 15071	15062 15072	15063 15073	15064 15074	15065 15075	
Dimensions (mm)	A	223	322	363	445	569
	B	216	316	356	438	563
	C	148	229	269	351	476
	∅D	16	16	16	16	16
Weight (kg)	0.3	0.6	0.7	0.9	1.2	

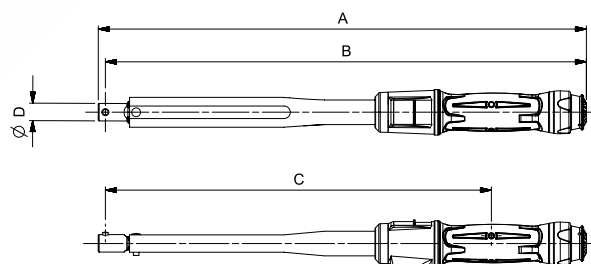

Female Torque Handle

Model	Pro 15 Pro 25	Pro 50	Pro 100	Pro 200 9 x 12 mm	Pro 200 14 x 18 mm	Pro 300	Pro 340	Pro 400	
Part Number	15100 15101 15110 15111	15102 15112	15103 15113	15104 15114	15105 15115	15106 15116	15107 15117	15108 15118	
Dimensions (mm)	A	218	325	365	442	453	570	662	664
	B	204	314	354	431	440	557	649	649
	C	139	227	267	345	353	440	562	563
	D	22	22	22	25	34	34	34	32
	E	20	20	20	20	26	28	28	24
Weight (kg)	0.3	0.6	0.7	0.9	1.0	1.2	1.3	1.7	

