



T-BOX™ 2



61908 TDMS USB Flash Drive

The T-Box™ 2 utilises its powerful processor to provide a seamless and complete torque data collection package. This is capable of tool calibrations, data logging, simultaneous transducer connections and archiving to your PC. As standard T-Box™ 2 is supplied with a UKAS accredited bi-directional calibration certificate recording each input as an independent channel.

- Instrument accuracy of $\pm 0.05\%$ ($\pm 0.1\%$ when below 10% of transducer capacity)
- System accuracy with a typical Norbar transducer, $\pm 0.5\%$ from 20% of transducer capacity
- 5 digit resolution when used with any Norbar transducer
- Features a 10.1" multi-touch screen display with on-screen graphic icons for simple and easy tool navigation and selection
- Features hardened and impact resistant glass helping to prevent chips and scratches appearing on the screen's surface
- 2 transducer ports gives you the ability to perform 2 tasks simultaneously e.g. graphing & measuring
- Two task windows allows simultaneous working. Measure against a target while graphing the cycle, take readings from two transducers simultaneously, capture two different graphs at the same time or manage and review readings as they are captured
- The T-Box™ 2 can capture graphs up to 325 Hz, offering the ability to analyse fast moving transients
- User configurable to allow a selection of Torque, Torque and Angle, rate targets and the ability to set thresholds
- Ability to predefine multiple targets
- 2 USB ports, 1 RS-232 serial port and 2 independently configurable ancillary ports
- Includes 6 modes for torque tool measurement: Track, Click, Dial & Electronic, Stall, Screwdriver and Hydraulic
- File browser/manager for internal storage and USB management giving the user greater ease and flexibility in managing multiple files and folders
- Can export readings and graphs to CSV and JSON format allowing for 3rd party software integration
- Ability to network via USB adapter
- Continuous output of up to 100 readings per second via RS-232 or USB virtual serial devices
- Fast CPU frequency up to 2.3 GHz
- Large capacity memory of 120 GB SSD storage
- 4GB RAM allows for smooth and seamless operation
- Bench stand supplied as standard with an adjustable viewing angle
- Rear panel features 100 mm x 100 mm VESA mounting holes, allowing for easy wall mounting or the use of third party stands / arms
- Software can be updated remotely, without the need to return the product to Norbar
- Fully supports the use of a keyboard and mouse (not supplied)

4	T-BOX 2
43542	T-Box 2 Instrument with TDMS Software



Displaying 2 transducer readings simultaneously

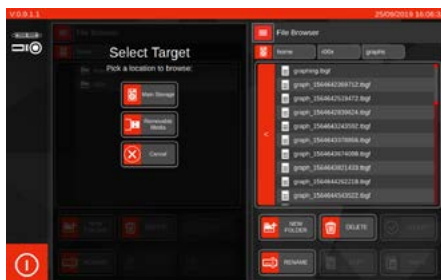

Storage destination (left) file browser (right)

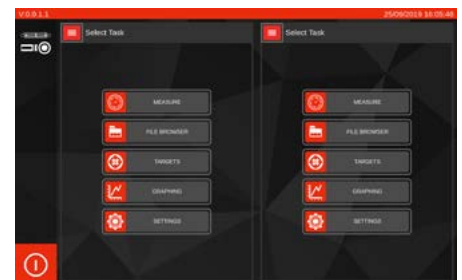

Home menu for 2 separate windows



T-BOX™ 2

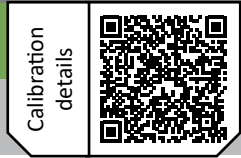

The Analogue Board (AnB) Module are more than just simple transducer inputs, they are distinct computing modules that operate independently containing their own states and settings. The T-Box™ 2 comes equipped with 2 of these modules inbuilt (image to the right). A good application for this would be the calibration of hydraulic torque wrenches where one AnB is configured to read a torque transducer and the other is configured to read a pressure transducer, allowing the user to build up a torque versus pressure graph using one instrument. See page 107 for a schematic example.

For situations where more than 2 transducers are required an external AnB module (43543 shown to the left) is available, this would also offer the advantage of being able to place the transducer at a distance to your T-Box™ 2 with no detrimental effects on the measurement signal.



Software version 1.0.3.1 available

- Ability to set up new graph pre-sets and defaults, saving the user time
- New graphing settings allows the user to set a maximum graph duration to stop data capture after a designated time
- Can link targets with the ability to delete previously captured result
- Intelligent target file history memorises the last-used files for individual AnB modules improving convenience when working with two transducers with different sets of targets at once
- Ability to enable or disable implicit AnB selection allowing for greater control when setting or clearing targets in AnB modules
- Users can now toggle serial data output on/off per AnB allowing the ability to suppress output from one AnB and leaving only the data stream from the AnB of interest
- Progressive Reset lets you sweep through a series of Linked Targets for the purpose of rapidly calibrating hydraulic wrenches or gearboxes, (peak-type modes only)

4	AnB MODULE
43543	T-Box 2 AnB Module

- Broadcast Capture Triggers lets you trigger capture of a reading on the neighbouring AnB when a reading capture is made on the target (peak-type and click modes only; peak-type modes require Progressive Reset to be enabled)
- Combining Progressive Reset and Broadcast Capture Triggers with Linked Targets to capture hydraulic wrench torque at a series of desirable pressure levels for rapid hydraulic wrench calibration. This approach can dramatically reduce calibration times (for instance, from several minutes to under 1 minute)
- Capture large numbers of readings with more fluidity than ever before thanks to performance optimisations in the user interface
- Simplified update procedure allowing for updates within T-Box™ 2 User Interface without the requirement of a keyboard

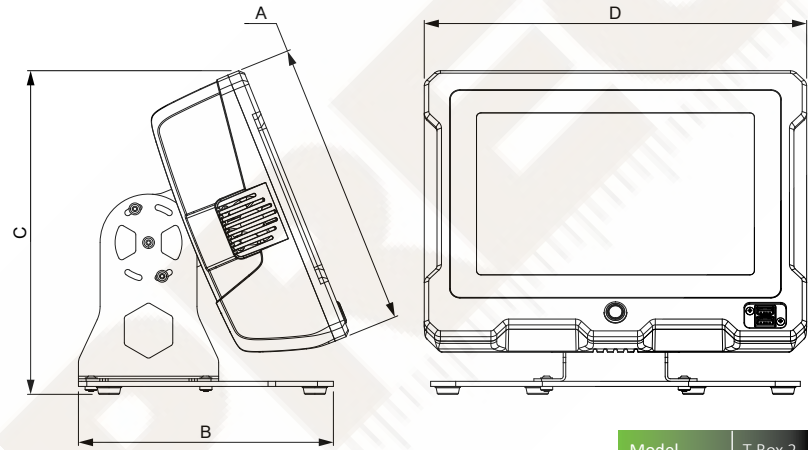

Displaying transducer reading alongside target selection

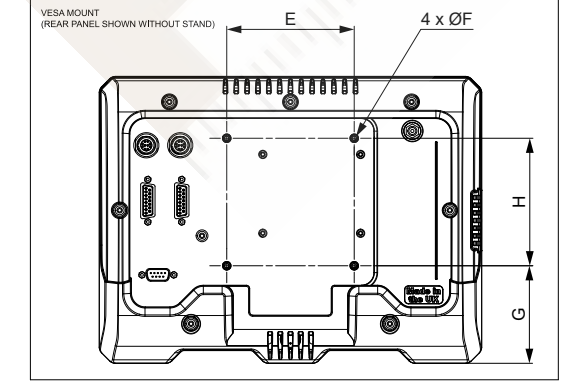

T-Box™ 2 back panel allows for 2 transducers to connect simultaneously, 1 RS-232 serial port and 2 ancillary ports

Model	T-Box 2	
Part Number	43542	
Dimensions (mm)	A	225
	B	200
	C	254
	D	300
	E	100
	ØF	M4
	G	76
	H	100
Weight (kg)	5.2	



T-Box™ 2 at the center of a test bench for manual torque wrenches, powered torque tools and hydraulic torque wrenches