



TEST RIGS AND FIXTURES



Universal Tool Test Rig (1½" M/F Static Transducer required (not included))



Power Tool Test Rig with Reaction Plates (50800)

4 7,000 N-m UNIVERSAL TOOL TEST RIGS	
50801	Universal 7,000 N-m ET, EBT, PT & Hydraulic Tool Test Rig (supplied with the 8 reaction plates (excluding blank reaction plate) and ¾", 1" and 1½" sq. dr. adaptors)
50804	Universal 7,000 N-m Test Rig without Reaction Plates (supplied with ¾", 1" and 1½" sq. dr. adaptors)

4 SPARES FOR 50800, 50801, 50803 & 50804	
50800.29	2" AF Socket 1½" sq. dr.
50800.28	2" AF Socket 1" sq. dr.
50800.27	2" AF Socket ¾" sq. dr.

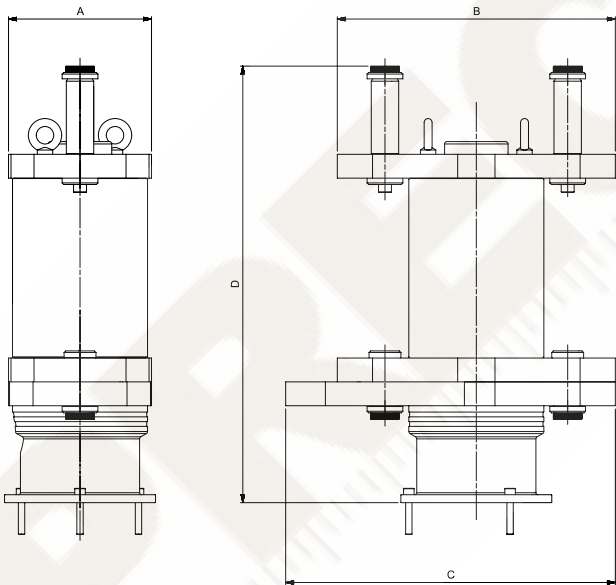

Model	Universal Tool Test Rig	
Part Number	50801, 50804	
Dimensions (mm)	A	180
	B	350
	C	415
	D	550
Weight (kg)	73.0	

See pages page 106 & page 107 for accessories for use with Hydraulic Tool Calibration Fixture

NOTE: Reaction plate dimensions can be found by searching their part number on the Norbar website

81041	Nut and bolt set for 7,000 N-m Power Tool Test Rigs
50548.4	Washer Stack Kit 100 - 7,000 N-m (Also for use with RD5000)

Universal Hydraulic Tool Test Rig with Reaction Plates (50801)



4 REACTION PLATES FOR USE WITH 50803 & 50804	
81024	Suitable for ET/EBT/PTS/PTM 119, PT 4500 and PT 5500
81025	Suitable for ET/EBT/PTS/PTM 92
81026	Suitable for ET/EBT/PTS/PTM 72
81027	Suitable for PTS/PTM 52
81028	Suitable for PT 2700
81030	Suitable for PT 5 and PT 6
81031	Suitable for PT 7
81032	Blank Reaction Plate for Universal Test Rigs