



## TORQUE SCREWDRIVER TESTER (TST)



Calibration details



The Torque Screwdriver Tester (TST) combines simplicity and functionality to provide a high quality instrument for the testing and calibration of low capacity torque tools.

The TST is supplied as standard with a UKAS accredited torque calibration certificate in CW direction for the complete system i.e. Supplied with Instrument certificate and internal transducer system certificate.

Featuring an internal transducer complete with Rundown Fixture, the TST is available in 3 torque ranges, 0.04 to 2 N·m, 0.5 to 10 N·m and 1.25 to 25 N·m. Class 1 system accuracy over its Primary range ( $\pm 0.5\%$  of reading from 20% to 100% of full scale).

What makes the TST genuinely versatile is the interface for an external transducer. This interface, accessed by a 2 way switch on the TST, allows the connection of any transducer from Norbar's Smart range and most mV/V calibrated transducers from Norbar or other manufacturers.

- Instrument accuracy of  $\pm 0.05\%$  ( $\pm 0.1\%$  when below 10% of transducer capacity)
- System accuracy with internal transducer or a typical external Norbar transducer,  $\pm 0.5\%$  from 20% of transducer capacity
- Pictorial display panel for easy mode selection
- Limit detection with low, pass and fail indication. Up to 12 target values can be set
- Digital limit state output for control of external tools
- Operation from fast charge internal battery pack (maximum time of 3 hours 20 minutes for full charge) or a.c. supply (90 to 264 Volts)
- RS-232-C serial data interface for connection to a printer or PC. Continuous RS-232 output when used in Track mode (up to 11 readings per second)
- Pulse count feature in Impulse mode and Clutch Tool mode
- Smart intelligence for transducer recognition
- Memory for calibration details of 20 non-Smart mV/V calibrated transducers
- Analogue output allows the instrument to be used as part of a process control system for performance analysis
- User-selectable frequency response for each mode of operation
- All user-selectable features have password protection. The instrument can be issued to users with only the required modes of operation and units of measure enabled. This feature can virtually eliminate operator induced errors
- $\frac{1}{4}$ " female hex to  $\frac{1}{4}$ " female square adaptor comes supplied as standard



4	TST SERIES 2
43212	TST 2, 0.04 - 2 N·m
43213	TST 10, 0.5 - 10 N·m
43214	TST 25, 1.25 - 25 N·m

12	
TST.CCW	UKAS-accredited counter-clockwise calibration when ordered with new unit

Above part numbers exclude Transducer lead for external transducer (see page 93).

TST is supplied complete with a Rundown Fixture for joint simulation. Additional rundowns are available see page 96.

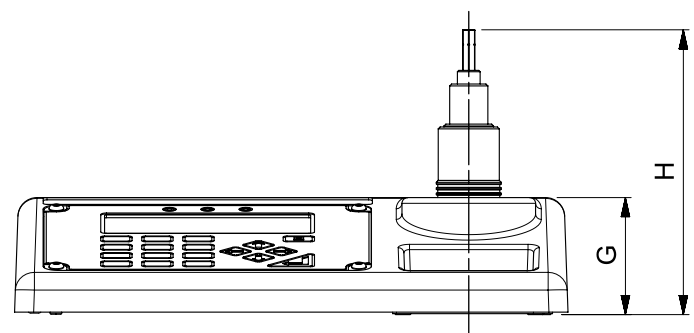
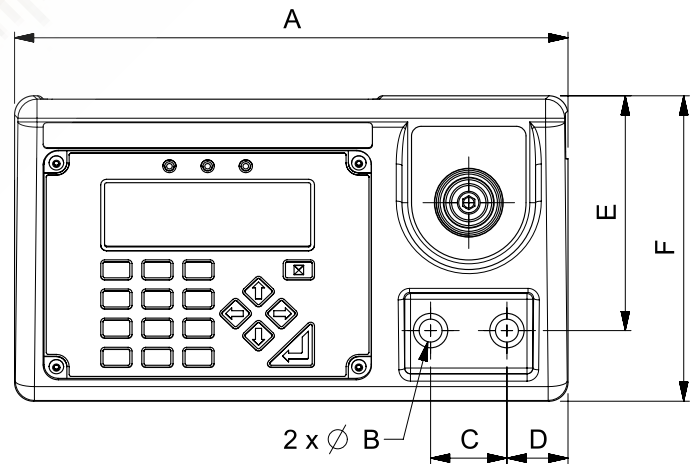

Model	All Models	
Part Number	43212 43213 43214	
Dimensions (mm)	A	290
	$\varnothing B$	10
	C	40
	D	32
	E	123
	F	160
	G	61
	H	149
Weight (kg)	4.7	