



TORQUE SCREWDRIVERS AND TORQUE WRENCHES



Torque Screwdrivers 14

Professional Torque Wrenches Model 5 14

Slimline™ Torque Wrenches 15

TT Torque Wrenches 16

TTi Non-Magnetic Torque Wrenches 16

Insulated Torque Wrenches 17

NorTorque® Tethered Torque Wrenches - for working at height 17

NorTorque® 18

Professional 'P' Type Torque Wrenches 20

Professional Torque Wrenches 22

Professional Torque Wrenches NLD Series 26

Industrial Torque Wrenches Adjustable & 'P' Type - New Generation 28

Industrial Torque Wrench - Bi-Square 30

Electrode Wrenches 30

Norbar Torque Tools manufacture an extensive range of high quality torque screwdrivers and torque wrenches to cover torque values from 0,3 N·m to 2,000 N·m. They are designed and manufactured to exceed international standards for accuracy.

In addition to the normal 'adjustable' torque wrenches, Norbar offer Production 'P' Type versions which can be pre-set and dedicated to a particular application. This setting system is designed to discourage unauthorised alteration.



TORQUE SCREWDRIVERS



Versatile, accurate and easy torquing for smaller fasteners and restricted spaces

- Accuracy to $\pm 6\%$ meets the requirements of ISO 6789-1:2017
- Supplied with $\frac{1}{4}$ " hexagon bit holder
- Single scale, either N·m or lbf·in

NOTE: Bit set is only sold separately or as part of kit - see website for bit set details

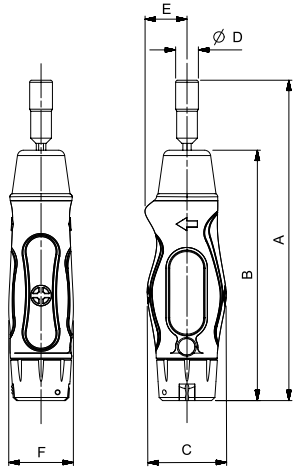

MODEL	ALL MODELS	
Dimensions (mm)	A	155
	B	121
	C	38
	$\varnothing D$	11
	E	20
	F	31
Weight (kg)	0.2	

2 ADJUSTABLE N·m

13850	TTs1.5, $\frac{1}{4}$ ", 0.3 - 1.5 N·m
13851	TTs3.0, $\frac{1}{4}$ ", 0.6 - 3 N·m
13852	TTs6.0, $\frac{1}{4}$ ", 1.2 - 6 N·m

2 ADJUSTABLE lbf·in

13853	TTs13, $\frac{1}{4}$ ", 2.5 - 13 lbf·in
13854	TTs26, $\frac{1}{4}$ ", 5 - 26 lbf·in
13855	TTs53, $\frac{1}{4}$ ", 10 - 53 lbf·in

2 PRODUCTION 'P' TYPE

13856	TTs1.5, $\frac{1}{4}$ ", 0.3 - 1.5 N·m, 2.5 - 13 lbf·in
13857	TTs3.0, $\frac{1}{4}$ ", 0.6 - 3 N·m, 5 - 26 lbf·in
13858	TTs6.0, $\frac{1}{4}$ ", 1.2 - 6 N·m, 10 - 53 lbf·in
SQ2222	Pre-set, etch and certify (Allow 3 days delivery for this service)

2 ADJUSTABLE N·m KIT

13700	TTs0.3 - 1.5 N·m Kit with 12 piece bit set and case
13701	TTs0.6 - 3 N·m Kit with 12 piece bit set and case
13702	TTs1.2 - 6 N·m Kit with 12 piece bit set and case
28937	12 Piece $\frac{1}{4}$ ", Hex bit set

PROFESSIONAL TORQUE WRENCHES MODEL 5



The Model 5 is a unique torque wrench that offers the convenience of interchangeable $\frac{1}{4}$ " hexagon bits. (ISO 1173:2001 Form C drive bits).

- Accuracy meets the requirements of ISO 6789-1:2017
- Non-length dependent. The Model 5 remains accurate regardless of hand position
- Supplied in a storage case. The case allows space for the storage of additional drive bits

2 ADJUSTABLE

13001	Pro 5, $\frac{1}{4}$ " female hex, 1 - 5 N·m
13002	Pro 5, $\frac{1}{4}$ " female hex, 10 - 50 lbf·in
13003	Pro 5, $\frac{1}{4}$ " female hex, 10 - 50 kgf·cm

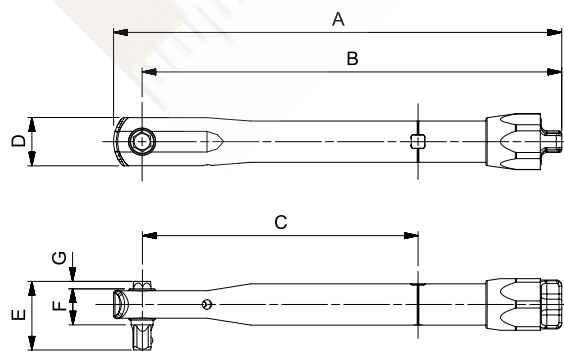

Also available as Production 'P' Types, preventing unauthorised alteration of torque setting. No external calibration equipment is required to set the Model 5 'P' Type.

2 PRODUCTION 'P' TYPE

13004	Pro 5, $\frac{1}{4}$ " female hex, 1 - 5 N·m
13005	Pro 5, $\frac{1}{4}$ " female hex, 10 - 50 lbf·in
13006	Pro 5, $\frac{1}{4}$ " female hex, 10 - 50 kgf·cm

8 MODEL 5 SPARES

28900	$\frac{1}{4}$ " Hex to $\frac{1}{4}$ " male square drive
-------	--



Model 5 'P' Type in storage case

Model	Adjustable	'P' Type	
Part Number	13001	13004	
	13002	13005	
	13003	13006	
	Dimensions (mm)	A	165
		B	155
		C	102
		D	18
E		25	
F	13		
G	2.8		
Weight (kg)	0.1	0.1	