



1

FORCE MEASUREMENT

Quick-Finder

Readout	Measuring range [Max]	Model	Page
[d] N	N	SAUTER	
0,001	2	FH 2	12
0,001	5	FH 5	12
0,002	5	FL 5	14
0,004	20	FS 2-20	16
0,004	20	FS 4-20	16
0,005	10	FH 10	12
0,005	10	FK 10	10
0,005	10	FL 10	14
0,01	1	283-152	8
0,01	10	FC 10	11
0,01	20	FH 20	12
0,01	25	FK 25	10
0,01	25	FL 20	14
0,01	50	FC 50	11
0,01	50	FH 50	12
0,01	50	FS 2-50	16
0,01	50	FS 4-50	16
0,01 0,05	1	289-100	6
0,02	3	283-252	8
0,02	50	FK 50	10
0,02	50	FL 50	14
0,02	100	FS 2-100	16
0,02	100	FS 2-100OY2	18
0,02	100	FS 4-100	16
0,04	200	FS 2-200	16
0,04	200	FS 4-200	16
0,05	6	283-302	8
0,05	10	FA 10	9
0,05	100	FH 100	12
0,05	100	FK 100	10
0,05	100	FL 100	14
0,05 0,5	5	289-102	6
0,1	10	283-402	8
0,1	20	FA 20	9
0,1	100	FC 100	11
0,1	200	FH 200	12
0,1	250	FK 250	10
0,1	250	FL 200	14
0,1	500	FC 500	11
0,1	500	FH 500	12
0,1	500	FH 500S71	24
0,1	500	FS 2-500	16
0,1	500	FS 2-500OY1	18
0,1	500	FS 2-500OY2	18
0,1	500	FS 4-500	16
0,1	500	FS 500G	20
0,1	500	FS 500G	20
0,1	500	TVL 500FHS71	24
0,1 0,5	10	289-104	6
0,2	25	283-422	8
0,2	500	FK 500	10

Readout	Measuring range [Max]	Model	Page
[d] N	N	SAUTER	
0,2	500	FL 500	14
0,2	500	FL 500G	20
0,2	500	FL 500G	20
0,2	500	FL 500G	20
0,2	1000	FS 2-1KOY2	18
0,2	1000	FS 2-1KSP1	18
0,25	50	FA 50	9
0,4	2000	FS 2-2KOY1	18
0,5	50	283-483	8
0,5	100	FA 100	9
0,5	1000	FH 1K	13
0,5	1000	FK 1K	10
0,5	1000	FL 1K	14
0,5	1000	FL 1KG	20
0,5	1000	FL 1KG	20
0,5	1000	FL 1KG	20
0,5	2500	FS 2-2KSP1	18
1	100	283-502	8
1	200	FA 200	9
1	1000	FC 1K	11
1	1000	FC 1K-BT	21
1	2000	FH 2K	13
1	2500	FL 2K	15
1	5000	FH 5K	13
1	5000	FS 2-5KOY1	18
1	5000	FS 2-5KRY1	18
1	5000	FS 2-5KSP1	18
2	200	283-602	8
2	5000	FL 5K	15
2	10000	FS 2-10KRY1	18
2	10000	FS 2-10KSP1	18
2,5	500	FA 500	9
2,5	500	FA 500G	20
2,5	500	FA 500G	20
2,5	500	FA 500G	20
4	20000	FS 2-20KOY1	18
4	20000	FS 2-20KSP1	18
5	500	283-902	8
5	10000	FH 10K	13
5	10000	FL 10K	15
5	25000	FS 2-25KRO1	18
10	20000	FH 20K	13
10	20000	FL 20K	15
10	50000	FH 50K	13
10	50000	FS 2-50KRO1	18
10	50000	FS 2-50KRY1	18
10	50000	FS 2-50KSP1	18
20	100000	FS 2-100KRO1	18
20	100000	FS 2-100KRY1	18
20	100000	FS 2-100KSP1	18
40	200000	FS 2-200KRY1	18
50	100000	FH 100K	13



SAUTER 289



SAUTER 287

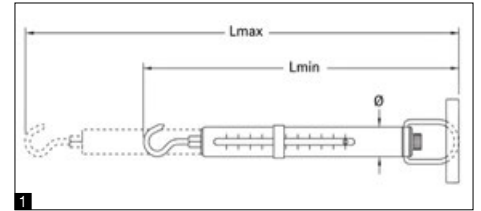

Discover more details and matching accessories online!

Mechanical weight and force measurement with quality spring for long service life

Features

- The very best price/performance ratio thanks to the transparent plastic housing, ideal for schools and educational institutions
- Newton scale: The SAUTER 289 range can display the results in Newtons instead of in grammes, specifically for measuring tensile forces
- Double scale: For fast or precise recording of the measurement result
- Backlash-free spring bearing with integrated tare screw for highly-precise adjustment
- Non-fatigue stainless steel spring

- Abrasion-resistant, colour precision scale with high resolution
- Thanks to the rotating inner tube, the scale is always easy to read
- The bracket which is delivered as standard can easily be swapped for another suspension device, so that the system can be individually adapted to the items being weighed

Technical data

- Measuring precision: $\pm 0,3\%$ of [Max]
- Tare range: 20 % of [Max]



Model	Measuring range [Max]	Division [d]	Load Support	1 Dimensions			Option
				Lmin	Lmax	Ø	Factory calibration certificate
SAUTER	N	N		mm	mm	mm	KERN
289-100	1	0,01 0,05	Hook	230	335	12,2	961-1610
289-102	5	0,05 0,5	Hook	230	335	12,2	961-1610
289-104	10	0,1 0,5	Hook	235	335	12,2	961-1610

Model	Measuring range [Max]	Division [d]	Load Support	1 Dimensions			Option
				Lmin	Lmax	Ø	Factory calibration certificate
SAUTER	g	g		mm	mm	mm	KERN
287-100	10	0,1	Clip	225	330	12,2	961-100
287-102	20	0,2	Clip	225	330	12,2	961-100
287-104	50	0,5	Clip	225	330	12,2	961-100
287-106	100	1	Clip	225	330	12,2	961-100
287-108	500	5	Clip	225	330	12,2	961-100
287-110	1000	10	Clip	225	330	12,2	961-100



SAUTER 281



SAUTER 285

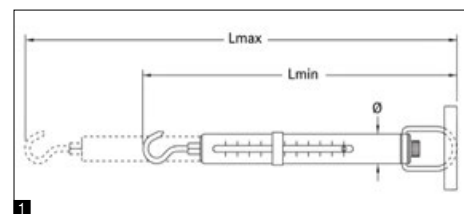

Discover more details and matching accessories online!

Precise, mechanical spring balances in robust aluminium housing with g/kg readout

Features

- Aluminium scale tube: robust, long service life, handy
- Gram/Kilogram scale: Measuring result display in grams/kilograms instead of N
- Double scale: For fast or precise recording of the measurement result
- Compressive force measurement: possible using an optional pressure set, see accessories
- Drag pointer and carrying handle: as standard for all models of the SAUTER 285 range

- Thanks to the rotating suspension bow the scale can always be aligned to be at the very best line of sight
- Backlash-free spring bearing with integrated tare screw for highly-precise adjustment
- Non-fatigue stainless steel spring
- Clip loop which can be freely rotated of the lower suspension bracket by 360° for models with $[Max] \leq 1 \text{ kg}$
- High-quality workmanship: Wear-resistant, colour-anodised precision scale with high resolution for accurate readability of the measuring result

Technical data

- Measuring precision: $\pm 0,3 \%$ of $[Max]$
- Tare range: 20 % of $[Max]$

STANDARD

OPTION



Model	Weighing range [Max] g	Division [d] g	Load support	1 Dimensions			Option
				Lmin mm	Lmax mm	Ø mm	Factory calibration certificate KERN
SAUTER							
281-101	10	0,1	Clip	220	300	12	961-100
281-151	30	0,25	Clip	220	300	12	961-100
281-201	60	0,5	Clip	220	300	12	961-100
281-301	100	1	Clip	220	300	12	961-100
281-401	300	2	Clip	225	325	12	961-100
281-451	600	5	Clip	225	325	12	961-100
281-601	1000	10	Clip	225	325	12	961-100
281-752	2500	20	Hook	225	325	12	961-100
285-052	5000	50	Hook	370	510	32	961-100
285-102	10000	100	Hook	370	510	32	961-101
285-202	20000	200	Hook	370	510	32	961-101
285-352	35000	500	Hook	370	460	32	961-101
285-502	50000	500	Hook	370	460	32	961-101

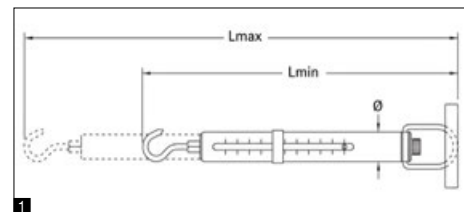

Discover more details and matching accessories online!

Precise, mechanical force gauge in robust aluminium housing with Newton readout

Features

- Aluminium scale tube: robust, long service life, handy
- Newton scale: Measuring result displayed in Newton
- Double scale: For fast or precise recording of the measurement result
- Compressive force measurement: possible using an optional pressure set, see accessories
- Carrying handle as standard
- Drag pointer as standard on all models of the SAUTER 283 range with [Max] ≥ 50 N

- Thanks to the rotating suspension bow the scale can always be aligned to be at the very best line of sight on all models of the SAUTER 283 range with [Max] ≥ 50 N
- Backlash-free spring bearing with integrated tare screw for highly-precise adjustment
- Non-fatigue stainless steel spring
- Clip loop which can be freely rotated of the lower suspension bracket by 360°
- High-quality workmanship: Wear-resistant, colour-anodised precision scale with high resolution for accurate readability of the measuring result

Technical data

- Measuring precision: ± 0,3 % of [Max]
- Tare range: 20 % of [Max]



Model	Measuring range [Max] N	Division [d] N	Load support	1 Dimensions			Option
				Lmin	Lmax	Ø	Factory calibration certificate
SAUTER							KERN
283-152	1	0,01	Hook	225	305	12	961-1610
283-252	3	0,02	Hook	225	325	12	961-1610
283-302	6	0,05	Hook	225	325	12	961-1610
283-402	10	0,1	Hook	225	325	12	961-1610
283-422	25	0,2	Hook	225	325	12	961-1610
283-483	50	0,5	Hook	370	510	32	961-1610
283-502	100	1	Hook	370	510	32	961-1610
283-602	200	2	Hook	370	510	32	961-1610
283-902	500	5	Hook	370	510	32	961-1610

FACE
LIFT



1



Discover more details and matching accessories online!

Mechanical force gauge with peak-hold function; new with sturdy aluminium housing and modern design

Features

- Mechanical force gauge for tensile and compressive force measurements
- Sturdy aluminium housing to protect the mechanics in the event of knocks or falls
- Modern, functional design
- Dual scale: shows Newton and kg
- Turnable display unit for an easy zero setting of the instrument
- Peak hold function by drag pointer
- Can be mounted on all manual test stands
- Zeroing by a short push of the switch
- **1** Standard attachments as shown, extension rod: 90 mm

Technical data

- Measuring precision: 1 % of [Max]
- Overall dimensions W×D×H 233×66×53 mm
- Thread: M6
- Net weight approx. 0,60 kg



Model	Measuring range [Max] N	Division [d] N	Option Factory Calibration Certificate		
			Tensile Force	Compressive Force	Tensile/Compressive Force
SAUTER			KERN	KERN	KERN
FA 10	10	0,05	961-1610	961-2610	961-3610
FA 20	20	0,1	961-1610	961-2610	961-3610
FA 50	50	0,25	961-1610	961-2610	961-3610
FA 100	100	0,5	961-1610	961-2610	961-3610
FA 200	200	1	961-1610	961-2610	961-3610
FA 500	500	2,5	961-1610	961-2610	961-3610

Further calibration options on request



Discover more details and matching accessories online!

Robust, digital force gauge for tensile and compressive force measurements

Features

- Turnable display: automatic direction identification
- Secure operability due to the ergonomic design
- Peak-Hold function to capture peaks (value is "frozen" for approx. 10 seconds) or Track function mode for a continuous measurement indication
- Selectable measuring units: N, lbf, kg, ozf
- Auto-Power-Off
- **1** Standard attachments as shown, extension rod: 90 mm
- Can be mounted on all SAUTER test stands up to 5 kN

Technical data

- Measuring precision: 0,5 % of [Max]
- Overload protection: 200 % of [Max]
- Overall dimensions W×D×H 195×83×35 mm
- Thread: M8
- Ready for use: Batteries included, 6×1.5 V AA
- Net weight approx. 0,75 kg

STANDARD



OPTION



Model	Measuring range [Max]	Readability [d]	Option Factory Calibration Certificate		
			Tensile Force	Compressive Force	Tensile/Compressive Force
SAUTER	N	N	KERN	KERN	KERN
FK 10	10	0,005	961-1610	961-2610	961-3610
FK 25	25	0,01	961-1610	961-2610	961-3610
FK 50	50	0,02	961-1610	961-2610	961-3610
FK 100	100	0,05	961-1610	961-2610	961-3610
FK 250	250	0,1	961-1610	961-2610	961-3610
FK 500	500	0,2	961-1610	961-2610	961-3610
FK 1K	1000	0,5	961-1620	961-2620	961-3620

1 ONLY WHILE STOCKS LAST
Further calibration options on request

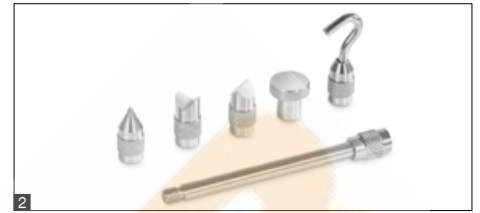

Discover more details and matching accessories online!

Compact force gauge for tensile and compressive force measurements

Features

- Turnable display with backlight
- Peak-Hold function to capture the peak value or Track function for continuous display of measurement
- Metal housing for durable use in harsh environmental conditions
- Capacity display: A bar lights up to show how much of the measuring range is still available
- Measuring with tolerance range (limit-setting function): Upper and lower limit adjustable, between 10 and 100 % of [Max], in pull and push direction. The process is supported by an acoustic and visual signal

- Safety: If loads exceed 110 % of the measuring range, the device will give clear acoustic and visual signals
- Internal memory for up to 500 measurement values
- USB data interface and USB interface cable as standard
- Selectable: AUTO-OFF function or permanent operation
- Selectable measuring units: N, kgf, ozf, lbf
- 1 Delivered in a robust carrying case
- 2 Standard attachments as shown, extension rod: 90 mm
- Can be mounted on all SAUTER test stands up to 5 kN

Technical data

- Measuring precision: 0,3 % of [Max]
- Transmission rate to PC: Up to 200 measured values/second
- Overload protection: 150 % of [Max]
- Overall dimensions W×D×H 145×73×34 mm
- Thread: M6
- Rechargeable battery pack integrated, as standard, operating time up to 20 h without backlight, charging time approx. 4 h
- Net weight approx. 0,50 kg

STANDARD



OPTION



Model	Measuring range [Max] N	Readability [d] N	Option Calibration certificate		
			Tensile Force DAkKS accr. KERN	Compressive Force DAkKS accr. KERN	Tensile/Compressive Force DAkKS accr. KERN
FC 10	10	0,01	963-161	963-261	963-361
FC 50	50	0,01	963-161	963-261	963-361
FC 100	100	0,1	963-161	963-261	963-361
FC 500	500	0,1	963-161	963-261	963-361
FC 1K	1000	1	963-162	963-262	963-362

Further calibration options on request

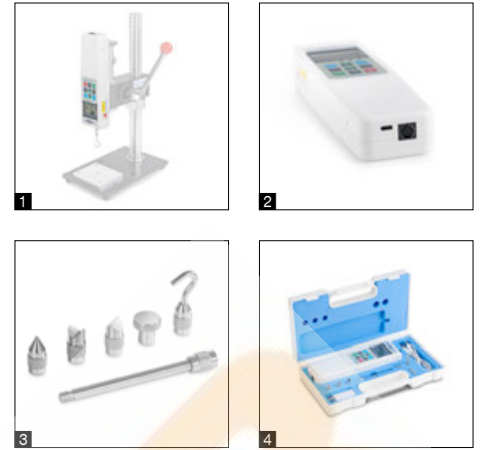

Discover more details and matching accessories online!

Universal digital force gauge for tensile and compressive force measurements with integrated load cell

Features

- Turnable display with backlight
 - **1** Can be mounted on all SAUTER test stands up to 5 kN
 - **2** USB interface for data transfer and power supply as standard
 - Data interface RS-232 as standard
 - Selectable measuring units: N, kgf, lbf
 - Peak-Hold function to capture the peak value or Track function for continuous display of measurement
 - Measuring with tolerance range (limit-setting function): Upper and lower limit adjustable, in pull and push direction.
- The process is supported by an audible and visual signal

Technical data

- Auto-Power-Off
- Internal memory for up to 10 measurement values
- Mini Statistics Kit: calculates the average result from up to 10 stored measured values, as well as min., max., n
- **3** Standard attachments as shown, extension rod: 90 mm, included with the delivery
- **4** Delivered in a robust carrying case

Technical data

- Transfer rate to PC: approx. 25 measured values per second
- Measuring precision: 0,5 % of [Max]
- Overload protection: 150 % of [Max]
- Thread: M6
- Overall dimensions W×D×H 240×70×40 mm
- Rechargeable battery pack integrated, as standard, operating time up to 40 h without backlight, charging time approx. 120 min
- External mains adapter, for connection to the USB-C connector, standard
- Net weight approx. 0,55 kg

STANDARD



OPTION



Model	Measuring range [Max]	Readability [d]	Option Calibration certificate		
			Tensile Force DAKkS accr. KERN	Compressive Force DAKkS accr. KERN	Tensile/Compressive Force DAKkS accr. KERN
SAUTER	N	N			
FH 2	2	0,001	-	-	-
FH 5	5	0,001	-	-	-
FH 10	10	0,005	963-161	963-261	963-361
FH 20	20	0,01	963-161	963-261	963-361
FH 50	50	0,01	963-161	963-261	963-361
FH 100	100	0,05	963-161	963-261	963-361
FH 200	200	0,1	963-161	963-261	963-361
FH 500	500	0,1	963-161	963-261	963-361

Further calibration options on request



Discover more details and matching accessories online!

Universal digital force gauge for tensile and compressive force measurements with external load cell

Features

- Turnable display with backlight
- **1** USB interface for data transfer and power supply as standard
- Data interface RS-232 as standard
- Selectable measuring units: N, kN, kgf, tf
- Peak-Hold function to capture the peak value or Track function for continuous display of measurement
- Measuring with tolerance range (limit-setting function): Upper and lower limit adjustable, in pull and push direction.
The process is supported by an audible and visual signal

- Auto-Power-Off
- Internal memory for up to 10 measurement values
- Mini Statistics Kit: calculates the average result from up to 10 stored measured values, as well as min., max., n
- Tension loops and compression plates are included in delivery
- **2** Delivered in a robust carrying case

Technical data

- Transfer rate to PC: approx. 25 measured values per second
- Measuring precision: 0,5 % of [Max]
- Overload protection: 150 % of [Max]
- Overall dimensions W×D×H 45×25×0 mm
- Rechargeable battery pack integrated, as standard, operating time up to 40 h without backlight, charging time approx. 120 min
- External mains adapter, for connection to the USB-C connector, standard
- Cable length approx. 3 m
- Net weight approx. 1,6 kg

STANDARD



OPTION



Model	Measuring range [Max] kN	Readability [d] N	Option calibration certificate DAkkS accur. (≤ 5 kN)/Factory calibration certificate (> 5 kN)		
			Tensile Force	Compressive Force	Tensile/Compressive Force
SAUTER			KERN	KERN	KERN
FH 1K	1	0,5	963-162	963-262	963-362
FH 2K	2	1	963-162	963-262	963-362
FH 5K	5	1	963-163	963-263	963-363
FH 10K	10	5	961-164	961-264	961-364
FH 20K	20	10	961-164	961-264	961-364
FH 50K	50	10	961-165	961-265	961-365
FH 100K	100	50	961-166	961-266	961-366

Further calibration options on request



Discover more details and matching accessories online!

Universal digital force gauge with graphic-assisted display and integrated load cell

Features

- Turnable display with backlight
- Peak-Hold function to capture the peak value or Track function for continuous display of measurement
- Metal housing for durable use in harsh environmental conditions
- Can be mounted on all SAUTER test stands up to 5 kN
- Capacity display: A bar lights up to show how much of the measuring range is still available
- Measuring with tolerance range (limit-setting function): Upper and lower limit adjustable, in pull and push direction.
The process is supported by a visual signal

- Internal memory for up to 500 measurement values
- Continuous analogue output: Linear voltage signal in dependence to the load (-2 to +2V)
- USB data interface, as standard
- Selectable measuring units: N, kN, kgf, lbf
- **1** Standard attachments: as shown
- **2** Delivered in a robust carrying case

Technical data

- Transfer rate to PC: approx. 25 measured values per second
- Measuring precision: 0,2 % of [Max]
- Overload protection: 120 % of [Max]
- Overall dimensions W×D×H 215×75×30 mm
- Thread: M6
- Rechargeable battery pack integrated, as standard, operating time up to 10 h without backlight, charging time approx. 8 h
- Net weight approx. 0,55 kg

STANDARD



OPTION



Model	Measuring range [Max] N	Readability [d] N	Option Calibration certificate		
			Tensile Force DAkkS accr. KERN	Compressive Force DAkkS accr. KERN	Tensile/Compressive Force DAkkS accr. KERN
SAUTER	N	N			
FL 5	5	0,002	-	-	-
FL 10	10	0,005	963-161	963-261	963-361
FL 20	25	0,01	963-161	963-261	963-361
FL 50	50	0,02	963-161	963-261	963-361
FL 100	100	0,05	963-161	963-261	963-361
FL 200	250	0,1	963-161	963-261	963-361
FL 500	500	0,2	963-161	963-261	963-361
FL 1K	1000	0,5	963-162	963-262	963-362

1 ONLY WHILE STOCKS LAST
Further calibration options on request



Discover more details and matching accessories online!

Powerful digital force gauge with graphic assisted display for tensile and compressive force measurements with external load cell

Features

- Premium force gauge with external measuring cell, tension loops included with delivery
- Turnable display with backlight
- Peak-Hold function to capture the peak value or Track function for continuous display of measurement
- Metal housing for durable use in harsh environmental conditions
- Can be mounted on all SAUTER test stands starting 1 kN
- Capacity display: A bar lights up to show how much of the measuring range is still available
- Measuring with tolerance range (limit-setting function): Upper and lower limit adjustable, in pull and push direction.
The process is supported by a visual signal

- Internal memory for up to 500 measurement values
- Continuous analogue output: Linear voltage signal in dependence to the load (-2 to +2V)
- USB data interface, as standard
- Selectable measuring units: N, kN, kgf, ozf, lbf
- **1** Delivered in a robust carrying case

Technical data

- Transfer rate to PC: approx. 25 measured values per second
- Measuring precision: 0,2 % of [Max]
- Overload protection: 120 % of [Max]
- Overall dimensions WxDxH 175x75x30 mm
- Dimensions load cell WxDxH
76,2x51x19 mm (FL 2K),
76,2x51x28 mm (FL 5K, 10K, 20K)
- Thread: M12
- Rechargeable battery pack integrated, as standard, operating time up to 10 h without backlight, charging time approx. 8 h
- Net weight approx. 1,4 kg

STANDARD



OPTION



Model	Measuring range [Max]	Readability [d]	Option calibration certificate DAkkS accr. (≤ 5 kN)/Factory calibration certificate (> 5 kN)		
			Tensile Force	Compressive Force	Tensile/Compressive Force
SAUTER	N	N	KERN	KERN	KERN
FL 2K	2500	1	963-162	963-262	963-362
FL 5K	5000	2	963-163	963-263	963-363
FL 10K	10000	5	961-164	961-264	961-364
FL 20K	20000	10	961-164	961-264	961-364

1 ONLY WHILE STOCKS LAST
Further calibration options on request



Measurement of forces in different tensile or compression directions possible with only one measuring device



Supplied in a high-quality and robust system case (systainer® T-LOC) including plug-in power supply and USB cable type C

Premium force gauge with integrated load cell (optional) and connection possibility for up to 4 external load cells

Use with integrated load cell

The SAUTER FS premium force gauge has an load measuring cell for tensile and compressive force applications. Either mobile for rapid testing or stationary integrated into a test stand or production line, the multifunction display allows all the values recorded to be read off at a glance in real time. Via the integrated interface, the data can be sent to a PC or laptop for further processing.

Use with external load cells

The SAUTER FS premium force gauge is compatible with all SAUTER strain gauge measuring cells, see *Measuring Cells*. Up to 4 external measuring cells can be connected simultaneously.



Tip: Order the practical system case (systainer® T-LOC) for storing and transporting of accessories, clamps, sensors, etc. at the same time, SAUTER FS TKZ, see *Internet*



User-friendly touch pen for display included with the delivery



Simultaneous measurement on up to four channels. External sensors with sensor data memory, optionally available, see *Measuring Cells*



Compact force gauge with internal measuring cell (up to max. 500 N) for fast and mobile force measurements. Illustration shows optional accessories, SAUTER AE 500 screw tension clamp

Features

- 3,5" touchscreen with touch pen
- Standard version with 2 or 4 measuring channels for external force sensors (subsequently expandable from 2 to 4)
- An internal load cell is possible (is deactivated if an external load cell is connected)
- Suitable for 4-wire and 6-wire sensors with strain gauges
- Two-point adjustment with weights or numerical adjustment possible
- The specific data of an external sensor are stored directly in the connector
- USB interface for data transfer and power supply as standard
- Internal device memory (16 GB)
- Tolerance function
- Track function for continuous measurement display
- Peak value measurement

Technical data

- Resolution: up to 10000 points per measurement channel
- Storage of measured values as well as their transmission to the interface with up to 1000 Hz per measuring channel
- Measurement accuracy:
 - with internal load cell: 0.1 % of [Max]
 - with external load cell: among other things from the load cells used
- Overload protection: 150 % of [Max] with internal measuring cell
- Thread on load receptor: M6 (outer)
- Rechargeable battery pack integrated, as standard, operating time up to 8 h without backlight, charging time approx. 8 h
- External mains adapter, for connection to the USB-C connector, standard
- Overall dimensions W×D×H 71×31×180 mm
- Net weight approx. 0,40 kg

Optional calibration, see page 89
 Calibration is recommended for each measuring cell!
 Assembly and adjustment of measuring cell, connector and sensors must be ordered separately, see table below,
 SAUTER FS 401 - FS 408

Discover more details and matching accessories online!

Order example SAUTER FS force gauge with 2 load cells:

1×	FS 2-500	2-channel force gauge with integrated load cell for tension/compression force measurements
1×	963-361	DAkkS-accredited calibration certificate tension/compression force up to 500 N
1×	CO 100-Y1	Miniature compression load cell up to 1 kN
1×	FS 403	Two-point adjustment up to 2 kN, incl. plug and memory for SAUTER FS
1×	963-262	DAkkS-accredited calibration certificate compression force up to 2 kN
1×	CS 500-3P2	Stainless steel "S" load cell for tension/compression force up to 5 kN
1×	963-363	DAkkS-accredited calibration certificate tension/compression force up to 5 kN
1×	FS 404	Two-point adjustment up to 5 kN, incl. connector and memory for SAUTER FS

STANDARD

OPTION

Service required for use with external sensors

Model	Measuring range internal load cell [Max] N	Readability internal load cell [d] N	Internal load cell	Number of measuring channels
SAUTER				
FS 2	-	-	-	2
FS 2-20	20	0,004	•	2
FS 2-50	50	0,01	•	2
FS 2-100	100	0,02	•	2
FS 2-200	200	0,04	•	2
FS 2-500	500	0,1	•	2
FS 4	-	-	-	4
FS 4-20	20	0,004	•	4
FS 4-50	50	0,01	•	4
FS 4-100	100	0,02	•	4
FS 4-200	200	0,04	•	4
FS 4-500	500	0,1	•	4

Model	Adjustment of optional, external sensors	Measuring range [Max] kN
SAUTER		
FS 401	Numeric*	-
FS 402		0,5
FS 403		2
FS 404		5
FS 405	Two-point	20
FS 406		50
FS 407		120
FS 408		250

*only for sensors > 250 kN



Practical set of premium force gauge and measuring cell

Features

- Thanks to several versions, the pre-configured sets are suitable for tensile and compressive force measurements in a wide range of applications. The set includes the premium force gauge FS 2 and the necessary service FS 401 – FS 408
- It is supplemented optionally by:
 - FS SP1: 4-wire “S” measuring cell made of nickel-plated steel for force and mass measurement (CS P1). For tensile force and compressive force measurements, see larger picture
 - **1** FS RY1: Loadcell made of steel alloy (CR Y1). For tensile force and compressive force measurements
 - **2** FS RQ1: Load cell made of stainless steel (CR Q1). For compressive force measurements
 - **3** FS OY1: Miniature cylindrical load cell made from stainless steel (CO Y1). For compressive force measurements
 - **4** FS OY2: Miniature cylindrical load cell made from stainless steel (CO Y2). For tensile force and compressive force measurements

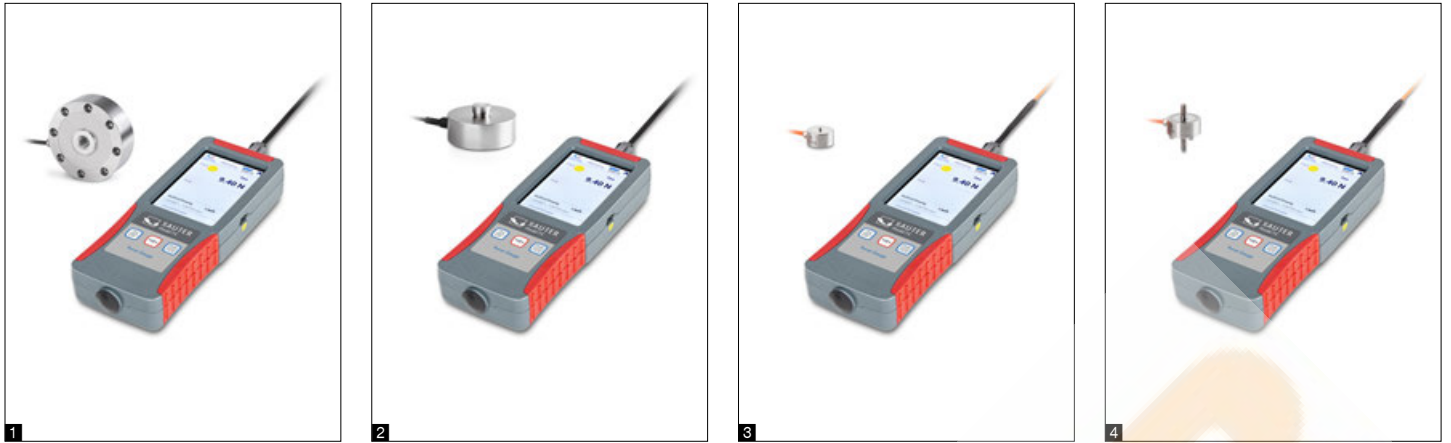

Discover more details and matching accessories online!

STANDARD

OPTION

DAkks ISO ≤ 5 kN

3 DAYS

Modell	Measuring range [Max] N	Readout [d] N	Load cell in the set	Option calibration certificate DAkks accr. (≤ 5 kN)/Factory calibration certificate		
				Tensile Force	Compressive Force	Tensile/Compressive Force
SAUTER				KERN	KERN	KERN
1 FS SP1: For tensile force and compressive force measurements						
FS 2-1KSP1	1000	0,2	CS 100-3P1	963-162	963-262	963-362
FS 2-2KSP1	2500	0,5	CS 250-3P1	963-163	963-263	963-363
FS 2-5KSP1	5000	1	CS 500-3P1	963-163	963-263	963-363
FS 2-10KSP1	10000	2	CS 1000-3P1	961-164	961-264	961-364
FS 2-20KSP1	20000	4	CS 2000-3P1	961-164	961-264	961-364
FS 2-50KSP1	50000	10	CS 5000-3P1	961-165	961-265	961-365
FS 2-100KSP1	100000	20	CS 10000-3P1	961-166	961-266	961-366
1 FS RY1: For tensile force and compressive force measurements						
FS 2-5KRY1	5000	1	CR 500-1Y1	963-161	963-263	963-363
FS 2-50KRY1	50000	10	CR 5000-1Y1	961-165	961-265	961-365
FS 2-100KRY1	100000	20	CR 10000-1Y1	961-166	961-266	961-366
FS 2-200KRY1	200000	40	CR 20000-1Y1	961-167	961-267	961-367
2 FS RQ1: For compressive force measurements						
FS 2-25KRQ1	25000	5	CR 2500-1Q1	-	961-265	-
FS 2-50KRQ1	50000	10	CR 5000-1Q1	-	961-265	-
FS 2-100KRQ1	100000	20	CR 10000-1Q1	-	961-266	-
3 FS OY1: For compressive force measurements						
FS 2-500OY1	500	0,1	CO 50-Y1	-	963-261	-
FS 2-2KOY1	2000	0,4	CO 200-Y1	-	963-262	-
FS 2-5KOY1	5000	1	CO 500-Y1	-	963-263	-
FS 2-20KOY1	20000	4	CO 2000-Y1	-	961-264	-
4 FS OY2: For tensile force and compressive force measurements						
FS 2-100OY2	100	0,02	CO 10-Y2	963-161	963-261	963-361
FS 2-500OY2	500	0,1	CO 50-Y2	963-161	963-261	963-361
FS 2-1KOY2	1000	0,2	CO 100-Y2	963-162	963-262	963-362



Fast testing of the stability of tombstones in accordance with VSG 4.7

SAUTER FA-G

- Pressure disc with foam rubber attachment
- Stainless steel handle with rubber covering for secure handling
- No electrical power supply required due to mechanical measuring system
- Real time or peak hold switch to observe transients or capture peaks by a drag indicator
- For tensile force and compressive force measurements
- Scope of delivery:
 - 1× FA 500
 - 1× AE 08
 - 1× AFH 04

SAUTER FL-G

- Ideal for the documented certification of specialist stone-cutter companies
- Rechargeable battery with long operating time (significantly more than 8 hours), so it is possible to use the device for a whole working day, in mobile mode
- Function to set limits: This is where you can program a stability limit value. If this limit value is exceeded, the device emits a visual signal. In this way, the measuring result does not need to be read off each time
- Wide pressure plate with foam rubber surface, so that the tombstone does not get scratched when force is applied
- Robust metal housing for permanent use under harsh environmental conditions
- Scope of delivery:
 - 1× FL 500/FL 1K
 - 1× AE 08
 - 1× AFH 04

SAUTER FS-G

- Through the internal and also external measuring cell it can also be used for more than just tombstone testing
- 3,5" touchscreen with touch pen
- USB interface for data transfer and power supply as standard
- Internal device memory (16 GB)
- Tolerance function
- Track function for continuous measurement display
- Peak value measurement
- Scope of delivery:
 - 1× FS 2-500
 - 1× AE 08
 - 1× AFK 02

Discover more details and matching accessories online!



STANDARD

STANDARD

STANDARD

OPTION

OPTION

SAUTER	FA 500G	FL 500G	FL 1KG	FS 500G
Measuring range [Max] N	500	500	1000	500
Readout[d] N	2,5	0,2	0,5	0,1
Measuring precision of [Max]	1 %	0,2 %	0,2 %	0,1 %
Overload protection of [Max]	150 %	120 %	120 %	150 %

Option	Tensile Force	961-1610,	961-161,	961-162,	961-161,
Factory calibration certificate	Compressive Force	961-2610,	961-261,	961-262,	961-261,
	Tensile/Compressive force	961-3610,	961-361,	961-362,	961-361,
Option	Tensile Force	-	963-161,	963-162,	963-161,
Calibration certificate	Compressive Force	-	963-261,	963-262,	963-261,
	Tensile/Compressive force	-	963-361,	963-362,	963-361,



Discover more details and matching accessories online!

Compact force measuring instrument

Features

- Checking the consistency of sprayed concrete is essential to ensure the maximum strength of the concrete during the curing process
- The FC 1K-BT determines exactly the forces required for the needle to penetrate the concrete. This allows reliable conclusions to be made regarding the compressive strength of the concrete during the dry phase
- Peak-Hold function to capture the peak value or Track function for continuous display of measurement
- Metal housing for durable use in harsh environmental conditions

- Capacity display: A bar lights up to show how much of the measuring range is still available
- Limit value function, programming of Max./Min., with output of acoustic and optical signal per ok indication
- Safety: If loads exceed 110 % of the measuring range, the device will give clear acoustic and visual signals
- Internal memory for up to 500 measurement values
- Turnable display with backlight
- Selectable: AUTO-OFF function or continuous operation, charge indicator
- **1** Delivered in a robust carrying case

Technical data

- Transmission rate to PC: up to 200 measured values/second
- Measuring precision: 0,3 % of [Max]
- Overload protection: 150 % of [Max]
- Housing dimensions WxDxH 145x73x34 mm
- Net weight approx. 1,8 kg
- Selectable measuring units: N, kgf, ozf, lbf
- Robust, cleanable and portable construction
 - Built-in 1000 N force measuring cell
 - Rapid and simple changing of the penetration needle
 - Inverted display for better readability
 - Live peak force value for immediate monitoring
 - Measurement precision $\pm 0,1 \%$
 - USB interface
- **2** Penetration needle and adapter
 - Removable if necessary
 - Needle diameter: 3 mm
 - Upper angle: 60 degrees
 - Length: 15 mm
 - Included: 15 needles

STANDARD



OPTION



Model	Measuring range [Max] N	Readability [d] N	Option Calibration certificate	
			Tensile Force DAkkS accr. KERN	Compressive Force DAkkS accr. KERN
SAUTER FC 1K-BT	1000	1	963-162	963-262

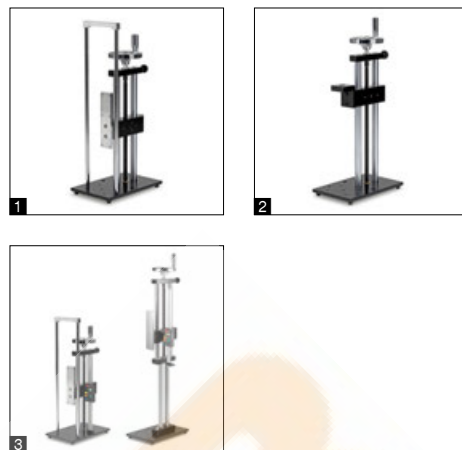

Discover more details and matching accessories online!

Manual test stand for highly accurate tensile and compressive force measurements

Features

- For vertical and horizontal use
- Precise measurement results
- High level of security at repeated measurements
- Large base plate with high versatility of fastening objects
- SAUTER TVL, TVL-XLS: Digital length meter SAUTER LA (without interface) as standard
 - Measuring range: max. 200 mm
 - Readability: 0,01 mm
 - Zero setting possible
 - Pre-length can be set manually
- **1** SAUTER TVL-O: Manual test bench without SAUTER LA length measuring device
- **2** SAUTER TVL-E: Test bench for force-measuring devices with an external measuring cell

SAUTER TVL-O, TVL-E:

- As an option, the SAUTER LB length measuring device (with interface) can be fitted, see internet
- SAUTER TVL, TVL-XLS, TVL-O: Suitable for all SAUTER force measuring devices with internal measuring cell up to 1000 N (not included in delivery)
- SAUTER TVL-E: Suitable for all SAUTER force measuring devices with external measuring cell up to 2000 N (not included in delivery)
- SAUTER TVL: Hook with M6 thread as standard
- SAUTER TVL-XLS: consisting of: SAUTER TVL + SAUTER TVL-XL, see internet
- **3** Model TVL and TVL-XLS in size comparison

Technical data

- Base plate with threaded hole M6
- Travel distance per knob rotation (stroke per one turn):
 - SAUTER TVL-XLS, TVL, TVL-O: 3 mm
 - SAUTER TVL-E: 2 mm

Save with our practical bundles of test stand, force gauge and matching clamps, e.g. SAUTER TVL 500FHS71, consisting of:

- 1× TVL
- 1× FH 500 (Details see page 12)
- 2× AE 500

You can find our bundles on page 24

STANDARD



TVL, TVL-XLS

Model	Measuring range [Max] N	Maximum travel distance mm	Length measuring device at delivery	Dimensions W×D×H mm	Net weight approx. kg
SAUTER TVL-XLS	500	230	Length measuring device with display	200×300×800	12
TVL	1000	230		151×234×465	9
TVL-O	1000	230	Length measuring device with display and data interface (optional)	151×234×465	9
TVL-E	2000	290		154×240×550	8



SAUTER TVP



SAUTER TVP-L

Discover more details and matching accessories online!

Manual test stands for compressive force measurements, also with digital length measurement

Features

- Provides quick and consistent testing
- High level of security at repeated measurements
- Provides maximum versatility and precise measuring results
- Slide construction for distance measurement
- Large base plate with high versatility of fastening objects
- Suitable for all SAUTER force gauges up to 500 N (not included in delivery)
- SAUTER TVP-L: Digital length meter
 - Measuring range: 100 mm
 - Readability: 0,01 mm
 - Zero setting possible
 - Pre-length can be set manually
 - without interface

Technical data

- Maximum work zone: 315 mm
- Maximum stroke length: 78 mm
- Base plate with threaded hole M6
- Overall dimensions W×D×H 150×233×420 mm
- Net weight approx. 11 kg

STANDARD



TVP-L

Model

Measuring range

SAUTER	[Max] N
TVP	500
TVP-L	500



Discover more details and matching accessories online!

The practical all-in-one package for rapid, simple testing

FH 500S71

- All-in-One: Digital force-measuring device incl. clamp
- For rapid, simple testing of forces up to 500 N
- Assembly and configuration of the parts is not required and therefore saves time and effort
- For tensile force and compressive force measurements

TVL 500FHS71

- All-in-One: test stand with digital force-measuring device and 2 clamps
- For manual testing with a pitch of 3 mm/rotation and for forces up to 500 N
- Assembly and configuration of the parts is not required and therefore saves time and effort
- For tensile force and compressive force measurements

STANDARD



OPTION



Model	Measuring range [Max] N	Division [d] N	Scope of delivery	Option Calibration certificate		
				Tensile Force DAkkS-accr. KERN	Compressive Force DAkkS-accr. KERN	Tensile/Compressive Force DAkkS-accr. KERN
FH 500S71	500	0,1	1× FH 500 1× AE 500	963-161	963-261	963-361
TVL 500FHS71	500	0,1	1× TVL 1× FH 500 2× AE 500	963-161	963-261	963-361



1

Discover more details and matching accessories online!





Robust premium test stand for laboratory applications

Features

- Motorised test stand for tension/compression force measurements
- Table-top design for comfortable operation
- Robust design for durable use
- Easy-to-access safety switch-off
- Upper and lower end point of the traverse distance can be set individually
- Automatic or manual operation mode
- **■** Suitable for all SAUTER force gauges up to 500 N, e.g. SAUTER FH-S, for details see (not included in delivery)

Technical data

- Maximum tensile and compressive force: 500 N
- Speed accuracy: 2 % of [Max]
- Overall dimensions W×D×H 570×428×236 mm
- Net weight approx. 28 kg

STANDARD	OPTION
 	 

Model	Measuring range	Speed range	Maximum travel distance
	[Max] N	mm/min	mm
SAUTER TVO 500N300	500	15 - 300	270



Premium test stand in table-top version – with precise step motor – also available as a set



Solid and flexible fixing options for many clamps and accessories from the SAUTER product range, see internet

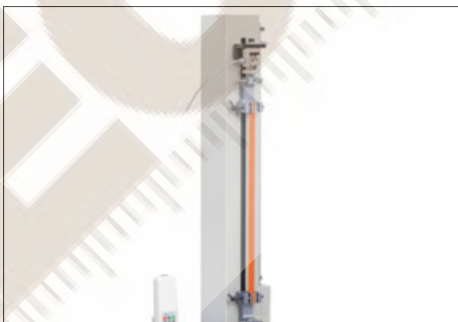

A wide range of application possibilities because of its large travelling distance



Interface for data transmission from the SAUTER FH measuring device and for controlling the test stand with SAUTER AFH software

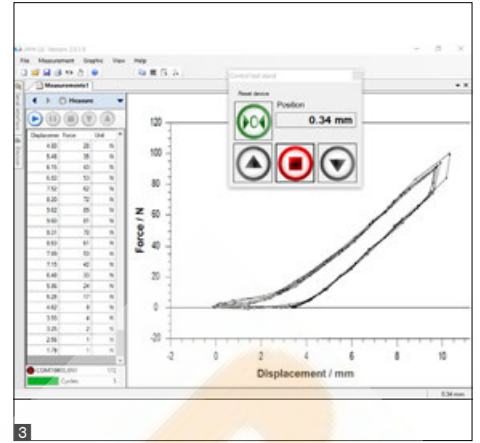

Features

- Motorised test stand for tension/compression force measurements. **1** Also available as a practical set TVO-LD for force-displacement-measurements in laboratory and industry
- Stepper motor for greatest ease of use
 - for constant speed from the smallest to the maximum load
 - allows testing at minimum speed and full load
 - for higher positioning accuracy.
- Precise starting and stopping, without overrun, even at high speeds
- precise adjustment of the displacement speed using the information shown on the display
- Automatic or manual operation mode
- **2** Premium operating panel:
 - Digital speed display
 - Digital repeat function display
 - Control of the test stand using PC software SAUTER AFH **3**
- Table-top design for comfortable operation
- Robust construction
- Fixation of SAUTER force measuring devices up to 2 kN possible

1 SAUTER TVO-LD

- Five in one – motorised test stand, length measuring system LD, interface cable, data transfer software AFH LD, interface converter AFH 12 and mounting
- With linear potentiometer for length measurement to create force-displacement diagrams on PC, maximum measuring range 300 mm / 500 mm / 700 mm, readability 0,01 mm, measuring accuracy 0.5 % of [Max], USB-A cable 1,5 m, high data acquisition speed

Technical data

- Speed accuracy: 0,5 % of [Max]
- Positioning accuracy when shutting down: ± 0,05 mm

Discover more details and matching accessories online!

STANDARD

OPTION

Model	Measuring range	Speed range	Maximum travel distance
	[Max] N	[Max] mm/min	mm
SAUTER			
TVO 500N500S	500	1 - 500	270
TVO 1000N500S	1000	1 - 500	500
TVO 2000N500S	2000	1 - 500	700
Sets incl. test stand, length measuring system, interface cable, software AFH LD, assembly:			
TVO 500N500S-LD	500	1 - 500	270
TVO 1000N500S-LD	1000	1 - 500	500
TVO 2000N500S-LD	2000	1 - 500	700



Motorised test stand incl. length measuring device LB

Test stand with electric motor for standard measurements – also available as a set



Premium operating panel
- Digital speed display
- Digital repeat function

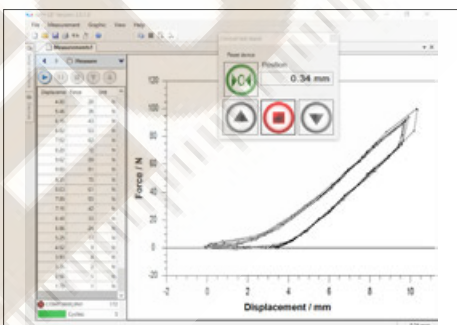

Control of the test stand using PC software SAUTER AFH



Solid and flexible fixing options of a wide range of clamps and accessories from the SAUTER range, see internet

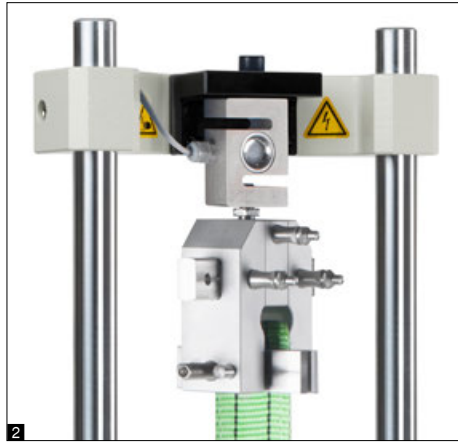

Features

- Motorised test stand for tension/compression force measurements. Also available as a practical set for force-displacement-measurements in laboratory and industry
- Force controlled automatic switchoff, teststop after achieving an adjusted limit load, only in connection with a SAUTER FH force gauge
- Maximum displacement protected by electronic end switches
- Particularly flexible mounting options for variable force SAUTER measuring devices, such as, FC, FH, FK, FL
 - **1** Direct mounting of measuring devices with internal load cell up to a measuring range of 500 N (only for TVM 5000N230N)
 - **2** Direct mounting of the external load cell on the traverse, starting with 1000 N measurement range and higher
 - Option: **3** Holder for force measuring devices of the SAUTER FH range with external load cell, see internet

SAUTER TVM-N/TVM-NL

- SAUTER LA length measuring device as standard, to read the travel distance with a readability of 0,01 mm

SAUTER TVM-LB

- Five in one – motorised test stand, digital length measuring device LB, interface cable, data transfer software AFH FD, two interface converters AFH 12 and mounting
- With digital length measuring device LB for creating force-displacement diagrams on the PC, maximum measuring range 300 mm, readability 0,01 mm

Discover more details and matching accessories online!

Technical data

- Maximum travel distance: 210 mm
- Speed accuracy: 3 % of [Max]



Model	Measuring range [Max] N	Speed range [Max] mm/min	Length of columns mm
SAUTER			
TVM 5000N230N	5000	10 - 230	635
TVM 5000N230NL	5000	10 - 230	1135
TVM 10KN120N	10000	30 - 120	1135
TVM 20KN120N	20000	30 - 120	1135
Sets incl. test stand, length measuring device, interface cable, software AFH FD, assembly:			
TVM 5000N230N-LB*	5000	10 - 230	635
TVM 5000N230NL-LB*	5000	10 - 230	1135
TVM 10KN120N-LB*	10000	30 - 120	1135
TVM 20KN120N-LB*	20000	30 - 120	1135

1 * ONLY WHILE STOCKS LAST



Motorised test stand incl. length measuring system LD

Premium test stand with step motor for precise testing up to 50 kN – also available as a set



Premium operating panel
 - Digital speed display for a direct reading of the displacement speed
 - Digital repeat function for long-term stress test

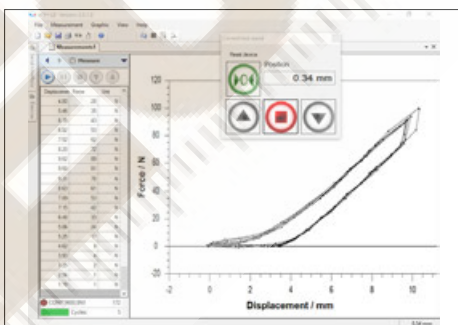

Control of the test stand using PC software SAUTER AFH



Solid and flexible fixing options for many clamps and accessories from the SAUTER product range, see internet

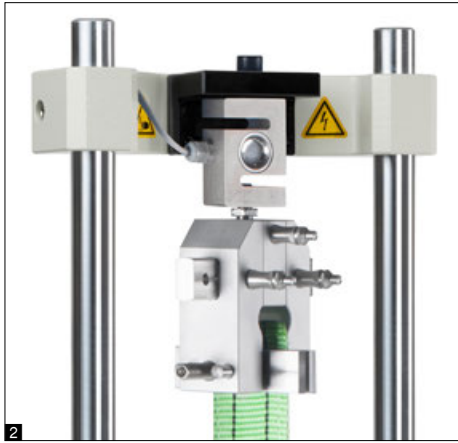

Features

- Motorised test stand for tension/compression force measurements. Also available as a practical set TVS-LD for force-displacement-measurements in laboratory and industry
- Stepper motor for greatest ease of use
 - for constant speed from the smallest to the maximum load
 - allows testing at minimum speed and full load
 - for higher positioning accuracy. Precise starting and stopping, without overrun, even at high speeds
 - precise adjustment of the displacement speed using the information shown on the display
- Maximum displacement protected by electronic end switches
- Large working area by means of long guide columns as standard, which allows a wide range of fixing options
- Particularly flexible mounting options for variable force measuring devices, such as, for example, SAUTER FC, FH, FK, FL:
 - ❶ Direct mounting of measuring devices with internal load cell up to a measuring range of 500 N (only for TVS 5000N240)
 - ❷ Direct mounting of the external load cell on the traverse, starting with 1000 N measurement range and higher
 - ❸ Option: Holder for force measuring devices of the SAUTER FH range with external load cell, see internet
- Only TVS: SAUTER LA length measuring device as standard, to read the travel distance with a readability of 0,01 mm

SAUTER TVS-LD

- Five in one – premium motorised test stand, length measuring system LD, interface cable, data transfer software AFH LD, interface converter AFH 12 and mounting
- With linear potentiometer for length measurement to create force-displacement diagrams on PC, maximum measuring range 300 mm, readability 0,01 mm, measuring accuracy 0.5 % of [Max], USB-A cable 1,5 m, high data acquisition speed

Discover more details and matching accessories online!

Technical data

- Maximum travel distance: 210 mm
- Speed accuracy: 1 % of [Max]
- Positioning accuracy when shutting down: ± 0,05 mm



Model	Measuring range [Max] N	Speed range [Max] mm/min	Length of columns mm
SAUTER			
TVS 5000N240	5000	1 - 240	1135
TVS 10KN100	10000	1 - 200	1135
TVS 20KN100	20000	1 - 100	1135
TVS 50KN80	50000	1 - 70	1135
Sets incl. test stand, length measuring system, interface cable, software AFH LD, assembly:			
TVS 5000N240-LD	5000	1 - 240	1135
TVS 10KN100-LD	10000	1 - 200	1135
TVS 20KN100-LD	20000	1 - 100	1135
TVS 50KN80-LD	50000	1 - 70	1135



NEW



Discover more details and matching accessories online!

Manual test stand with innovative quick adjustment for applications up to 7 kN

Features

- **1** Manual test stand with integrated quick adjustment of the upper crosshead for particularly easy height adjustment when changing test specimens
- Maximum force up to 7 kN
- Suitable for all SAUTER force gauges
- For vertical and horizontal use
- Readable scale with zero setting function for convenient reading of the length value
- Large base plate with high versatility of fastening objects
- Easily expandable or modifiable thanks to modular system

Technical data

- Base plate with threaded hole M 12
- Travel distance per knob rotation (stroke per one turn): 0,8 mm
- Total spindle stroke: 100 mm
- Overall dimensions W×D×H 480×530×1060 mm
- Net weight approx. 28 kg

Main scope of applications

- Automotive industry
- Electrical engineering and electronics
- Plastics and rubber industry
- Metal processing
- Packaging industry
- Research and development / test laboratories
- Quality assurance / incoming goods inspection

STANDARD



Model

Measuring range

SAUTER

[Max]
N

TVQ



7000

FASTENERS & ACCESSORIES

It is often the little details that make a crucial difference. Fasteners such as clamps and brackets are small but essential connecting elements between measuring devices and test benches or workpieces. Precise and reproducible measurements would not be possible without them.

In addition to a wide selection of fasteners, SAUTER also offers suitable accessories to provide you with the ideal support for your measurements. Whether standard or customised solutions, our range has everything you need for precise and efficient measuring.

Our experts are at your side with their specialised knowledge to help you select the best components for your measuring systems.



Accessories



Jaws

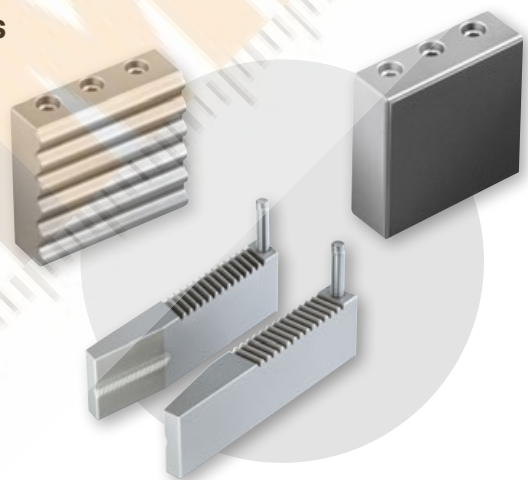

Clamps

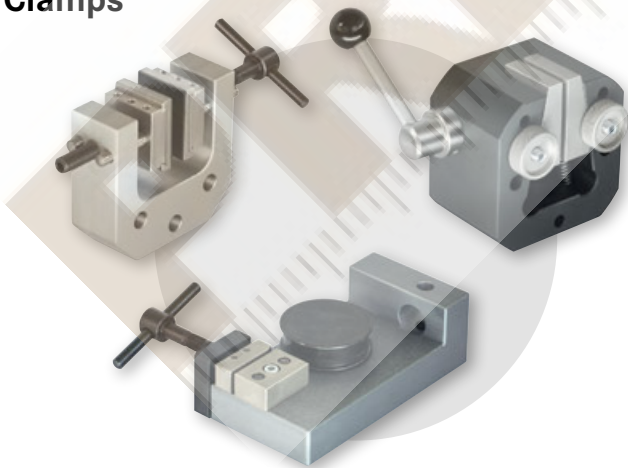

Connection adapters



You can find the full range of clamps & brackets as well as the entire assortment of accessories with many other parts on the internet.

Or you can simply scan the code for detailed information, technical data and prices.

INDIVIDUAL CUSTOMIZED SOLUTIONS DESIGNED TO YOUR REQUIREMENTS

You haven't found a matching clamping solution in our assortment?

No problem, we will develop the matching clamping system that is tailored to your test system. With innovative solutions and many years of experience, we provide your team or company with technological support and jointly develop the suitable clamping system.

CUSOS – perfectly tailored to you and your requirements

The development of your customised clamping system is carried out using the latest technologies. From the idea, during the development, the manufacturing process, to the finished product, we and our partners use the latest and most modern techniques.

Contact us today and ask for your individual solution.

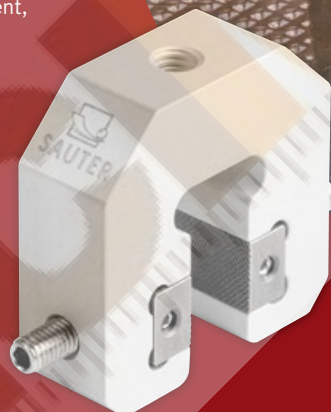

CUSTOMIZED
SOLUTION SERVICE

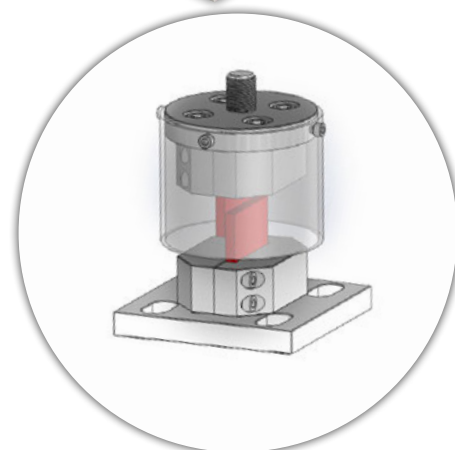
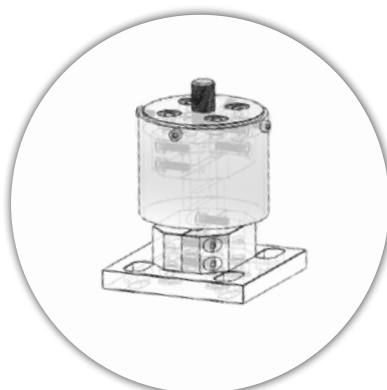
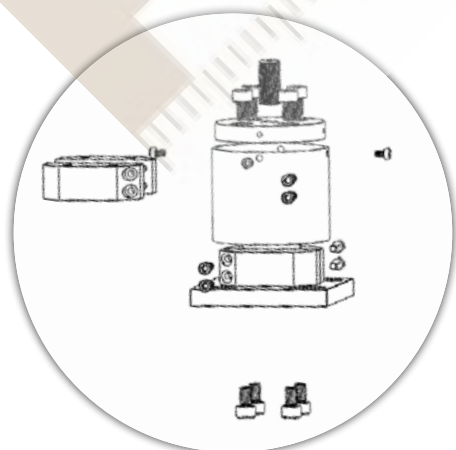
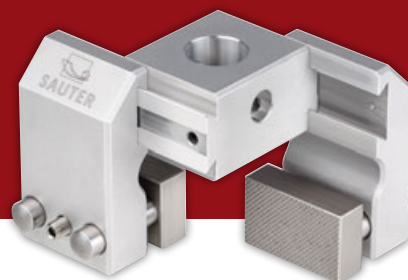

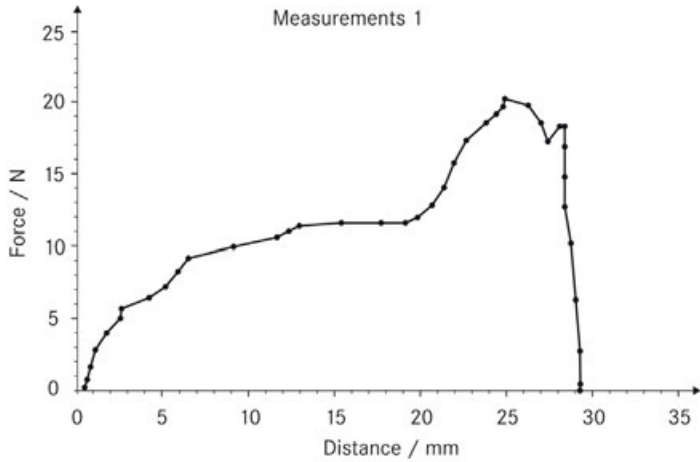

Discover more details and matching accessories online!

Data transfer software for force-displacement-measurements

Features

- AFH LD software is designed for all applications that require the measurement of forces, depending on the displacement. Typically these are force progression graphs in penetration tests or pullout tests
- The program simultaneously requests the measurements from a force measuring device, e.g. SAUTER FH, as well as a length measuring device, SAUTER LD 1, 2
- The measurements from both instruments are transferred continuously to the PC, synchronised by the AFH LD software and exported in the form of a graphic, as well as free data format for simple processing in Microsoft Excel®
- The software AFH LD is compatible with all instruments of series SAUTER FC, FH, FL, FS
- The SAUTER LD length measuring device is compatible with the SAUTER TVO and TVS motorised test benches

Further analysis functions:

- Extension of the test object
- Tensile and compressive force
- Endurance testing
- Archiving the recorded data

Scope of delivery:

- Software AFH LD as download
- User manual

- Compatible with the following operating system: Microsoft Windows® 10, 11

SAUTER AFH LD

- Force-displacement software, but only in combination with a length measuring device of SAUTER LD series

Technical data

- Data recording rate max. 25 Hz (in combination with SAUTER LD, dependent on measuring instrument)

STANDARD



Model

SAUTER

AFH LD

No.	Messwert	Einheit	Richtung	Material	Datum	Zeit
6	182	HL	0	Steen&Cast Steel	11. Mai	21:00
7	608	HL	0	Steen&Cast Steel	11. Mai	21:00
8	343	HL	0	Steen&Cast Steel	11. Mai	21:00
9	343	HL	0	Steen&Cast Steel	11. Mai	21:00
10	480	HL	0	Steen&Cast Steel	11. Mai	21:00
11	629	HL	0	Steen&Cast Steel	11. Mai	21:00
12	800	HL	0	Steen&Cast Steel	11. Mai	21:00
13	597	HL	0	Steen&Cast Steel	11. Mai	21:00
14	647	HL	0	Steen&Cast Steel	11. Mai	21:00
15	596	HL	0	Steen&Cast Steel	11. Mai	21:00
16	595	HL	0	Steen&Cast Steel	11. Mai	21:00
17	629	HL	0	Steen&Cast Steel	11. Mai	21:00
18	595	HL	0	Steen&Cast Steel	11. Mai	21:00
19	599	HL	0	Steen&Cast Steel	11. Mai	21:00
20	598	HL	0	Steen&Cast Steel	11. Mai	21:00
21	603	HL	0	Steen&Cast Steel	11. Mai	21:00
22	592	HL	0	Steen&Cast Steel	11. Mai	21:00
23	590	HL	0	Steen&Cast Steel	11. Mai	21:00
24	609	HL	0	Steen&Cast Steel	11. Mai	21:00
25	591	HL	0	Steen&Cast Steel	11. Mai	21:00

Discover more details and matching accessories online!

Plug-In for data transfer of measuring data from the measuring instrument and transfer to a PC, e.g. in Microsoft Excel®

Features

- Ideal for transferring measuring data from the internal data memory of the measuring instrument to Microsoft Excel®
- Solution: SAUTER AFI-2.0 plug-in for Microsoft Excel®. By doing this, an installation and learning yet another software can be avoided
- Compatible with Microsoft Excel® 2013 et seq.
- Easy handling: The measuring instrument is connected to the PC. At the push of a button, the SAUTER AFI-2.0 plug-in scans all the existing serial interfaces on the PC, finds the relevant measuring instrument and then reads the measuring data memory

Technical data

- Suitable for the following ranges:
SAUTER FL, FS, DA, DB, HN-D, HK-D, HK-DB, SW

STANDARD

